

クローラークレーン

120t

KOBELCO 7120G

▶主要諸元 (型式 : 7120G)

項目	仕様	仕様	
		クローラークレーン	ラフティングタワー
最大つり上げ能力	t×m	120×5.0	20×15.0
ブーム(タワー)長さ	m	15.2~61.0	30.4~51.7
		61.0~79.2(ロング)	
ジブ(タワージブ)長さ	m	12.2~30.5	22.9~44.2
最大ブーム(タワー)+ジブ(タワージブ)長さ	m	61.0+30.5	51.7+44.2
ロープ速度	主巻 巻上・巻下 m/min	*120~3	
	補巻 巻上・巻下 m/min	*120~3	-
	タワージブ起伏 巻上・巻下 m/min	-	*60~3
	サード(オプション) 巻上・巻下 m/min	*110~3	-
	ブーム(タワー)起伏 巻上・巻下 m/min	*48~2	
回転速度	min ⁻¹ {rpm}	2.1{2.1}	
走行速度	km/h	*1.3/0.9	
作業時質量(基本姿勢)	t	120	130
接地圧(基本姿勢)	kPa{kgf/cm ² }	93.6{0.95}	101.5{1.03}
登坂能力(tanθ)	%(度)	30(16.7)	-
定格ラインプル	kN{tf}	118{12.0}	-
エンジン	名称	日野P11C-VC	
	定格出力	kW/min ⁻¹ 271/1,850	
ワイヤロープ	主巻	mm	φ26
	補巻(タワージブ)	mm	φ26
	ブーム(タワー)	mm	φ20

サードドラムはオプションです。

各ロープ速度はドラム1層目での値です。

*印の速度は軽負荷の時の値であり、負荷により速度の変動があります。

単位は国際単位系のS I単位で、{|}内は従来表示です。

▶フック巻上限界 (単位 : m)

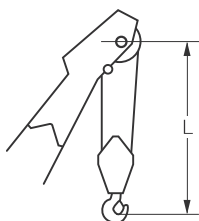

使用フック	L
120 tフック	5.0
70 tフック	5.0
35 tフック	5.0

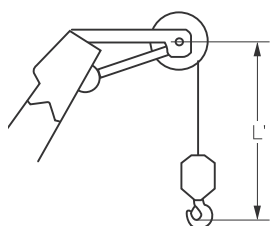

使用フック	L'
ボールフック	4.2

▶仕様とアタッチメント (クローラークレーン/ラフティングタワー)

アタッチメント	仕様	
	クローラークレーン	ラフティングタワー
4.6m上部ブーム	◎	-
3.0m中間テーパーブーム*1	◎	-
1.4mタワーキャップ	-	◎
7.6m下部ブーム(共用)	◎	
3.0m中間ブーム(ケーブルローラ付・共用)	○	◎
6.1m中間ブーム(ケーブルローラ付・共用)	○	○
9.1m中間ブーム(ケーブルローラ付・共用)*2	○	◎
9.1mタワー専用中間ブーム	○兼用可	◎
4.6m上部ジブ	○	-
4.6m下部ジブ	○	-
3.1m中間ジブ	○	-
6.0m中間ジブ	○	-
7.6m上部タワージブ*3	△	◎
6.1m下部タワージブ	-	◎
3.0m中継ジブ*4	△	◎
3.0m中間タワージブ*5	△	◎
6.1m中間タワージブ*5	△	◎
9.1m中間タワージブ*5	△	○
120tフック(5枚シーブ)	◎	-
70tフック(3枚シーブ)	○	-
35tフック(1枚シーブ)	○	◎
ボールフック	○	
補助シーブ	○	-
主巻ワイヤロープ(φ26×275m)	◎	-
補巻ワイヤロープ(φ26×255m)	○	-
ブーム(タワー)起伏ワイヤロープ(φ20×190m)	◎	◎
タワー主巻ワイヤロープ(φ26×290m)	-	◎
タワージブ起伏ワイヤロープ(φ26×145m)	-	◎
タワーブーム起伏ワイヤロープ(φ20×190m)	-	◎

◎印は基本仕様、○印は選択可能なアタッチメントを示します。

△印はロングブームを構成する場合に必要なアタッチメントを示します。

*1 クローラークレーンの上部ブームまたはロングブームとセットで使用します。

*2 クローラークレーンの中間ブームに転用できます。

*3 ロングブーム仕様では上部ブームとして使用します。

*4 ロングブーム仕様では3.0mテーパーブームと、ラフティングタワーでは下部タワージブとセットで使用します。

*5 ロングブーム仕様で中間ブームとして使用します。

クローラークレーン

▶全体図(単位: mm)

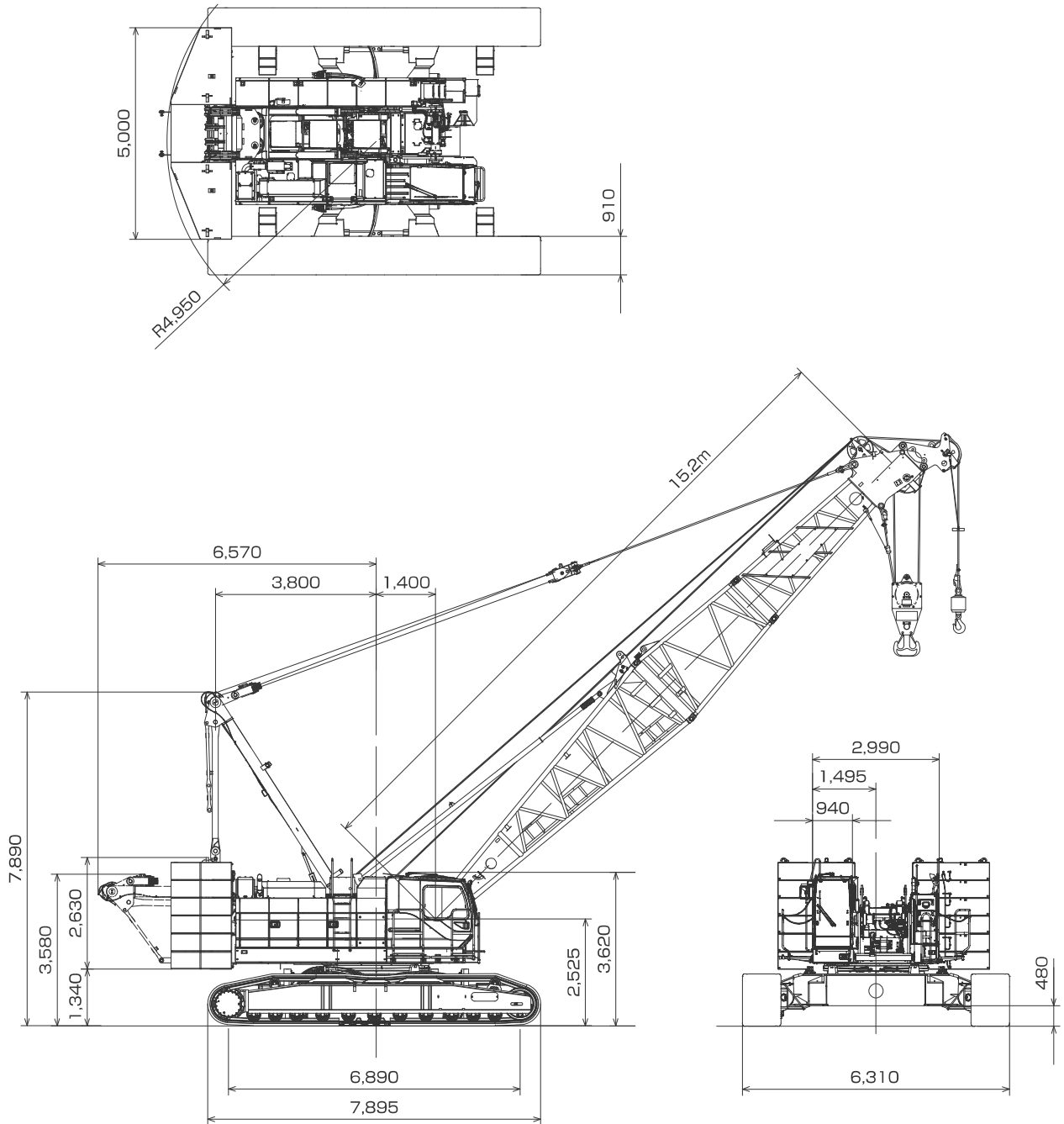

▶ブーム構成

- ↗印は、ジブ使用時のガイドライン取付位置を示します。
- ※印は、これより短いブームの組立可能な構成を示します。
- 使用するガイドラインの径はφ30mmです。

中間ブームの種類		
記号	ブーム長さ	備考
3.0	3.0m	ブーム
6.1	6.1m	ブーム
9.1	9.1m	ブーム
3.0T	3.0m	テーパブーム
3.0A	3.0m	中継ジブ
3.0	3.0m	タワージブ
6.1	6.1m	タワージブ
9.1	9.1m	タワージブ

ブーム長さ m (ft.)	ブーム構成
15.2 (50)	
18.3 (60)	※
21.3 (70)	※
24.4 (80)	※
27.4 (90)	※
30.5 (100)	※
33.5 (110)	※
36.6 (120)	※
39.6 (130)	※

ブーム長さ m (ft.)	ブーム構成
42.7 (140)	※
45.7 (150)	※
48.8 (160)	※
51.8 (170)	※
54.9 (180)	※
57.9 (190)	※
61.0 (200)	※

▶ロングブーム構成

- *印は、これより短いブームの組立可能な構成を示します。
- 使用するガイラインの径はφ30mmです。

ブーム長さ m (ft.)	ブーム構成/ロング
61.0 (200)	
64.0 (210)	*
67.1 (220)	*
70.1 (230)	
73.2 (240)	*
76.2 (250)	
79.2 (260)	

▶ジブ構成

- ジブを装着できる主ブームの長さは、24.4m (80) ~ 61.0m (200) です。

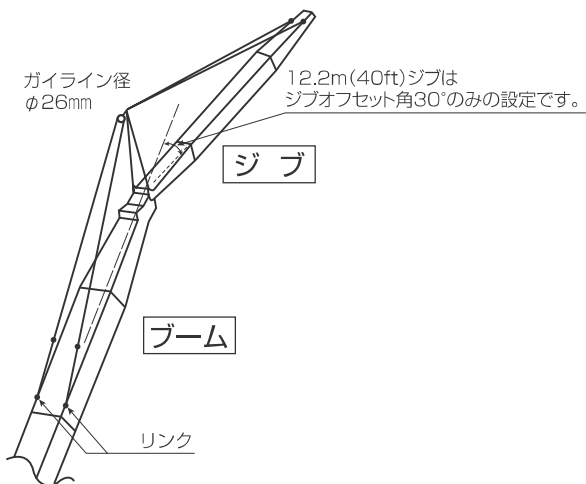

ジブ長さ m (ft.)	ジブ構成	オフセット角
12.2 (40)		30°
18.3 (60)		10°/30°
24.4 (80)		10°/30°
30.5 (100)		10°/30°

▶作動範囲図

▣主ブーム

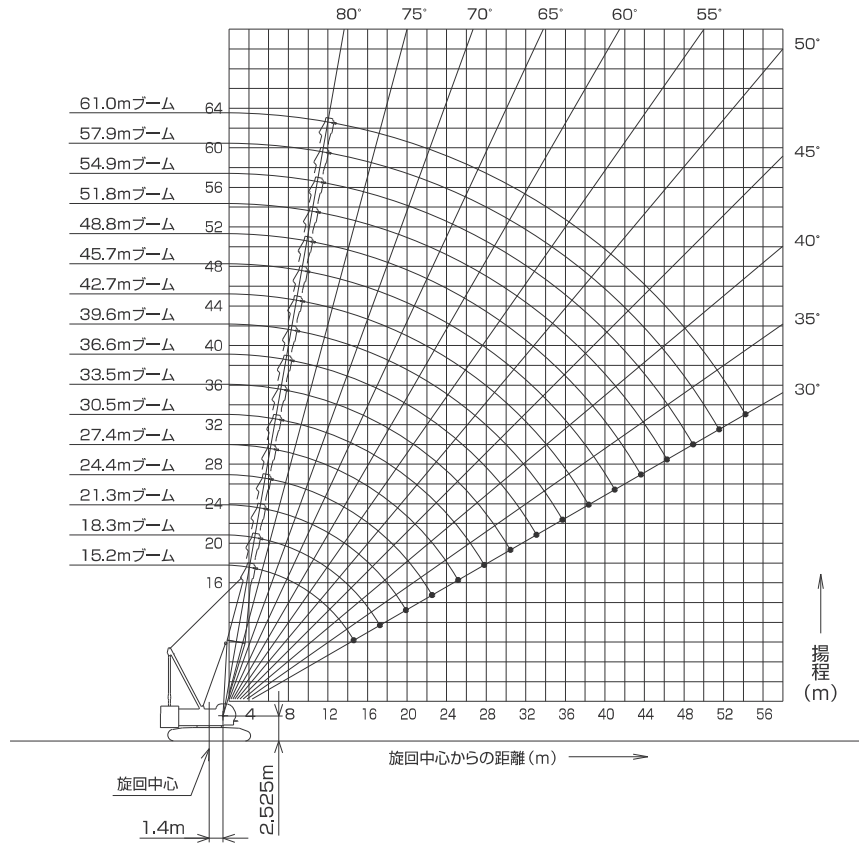

▶ロングブーム

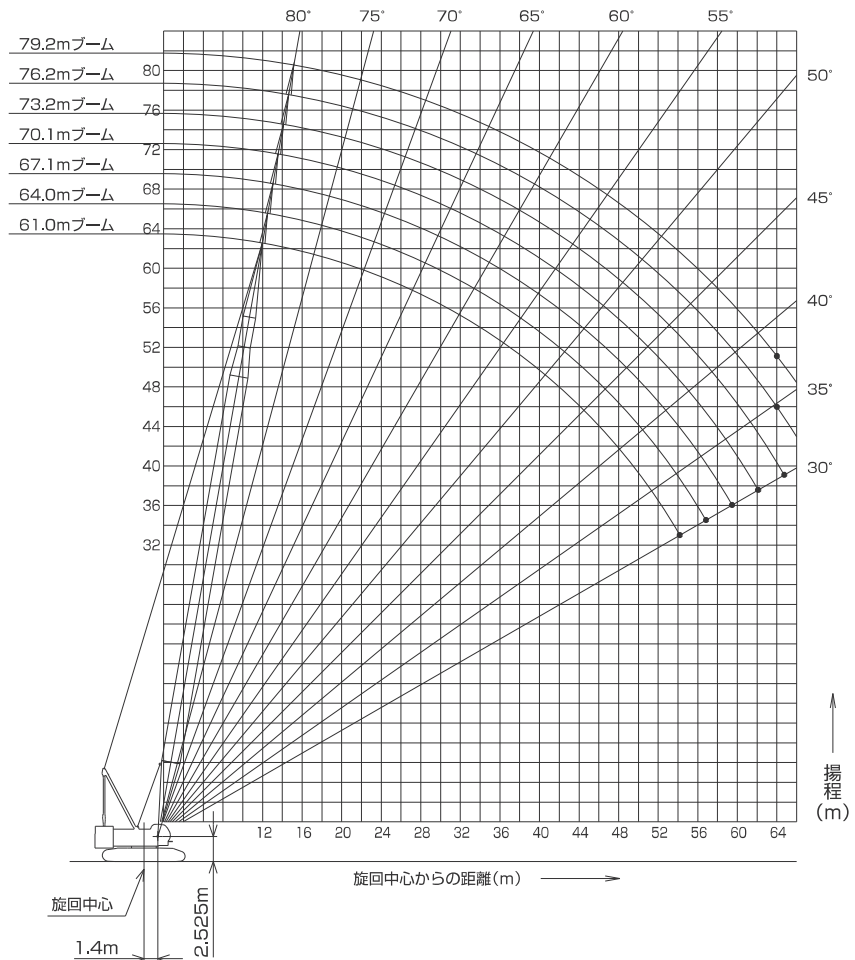

■ジブ装着
(オフセット角度10°/30°)

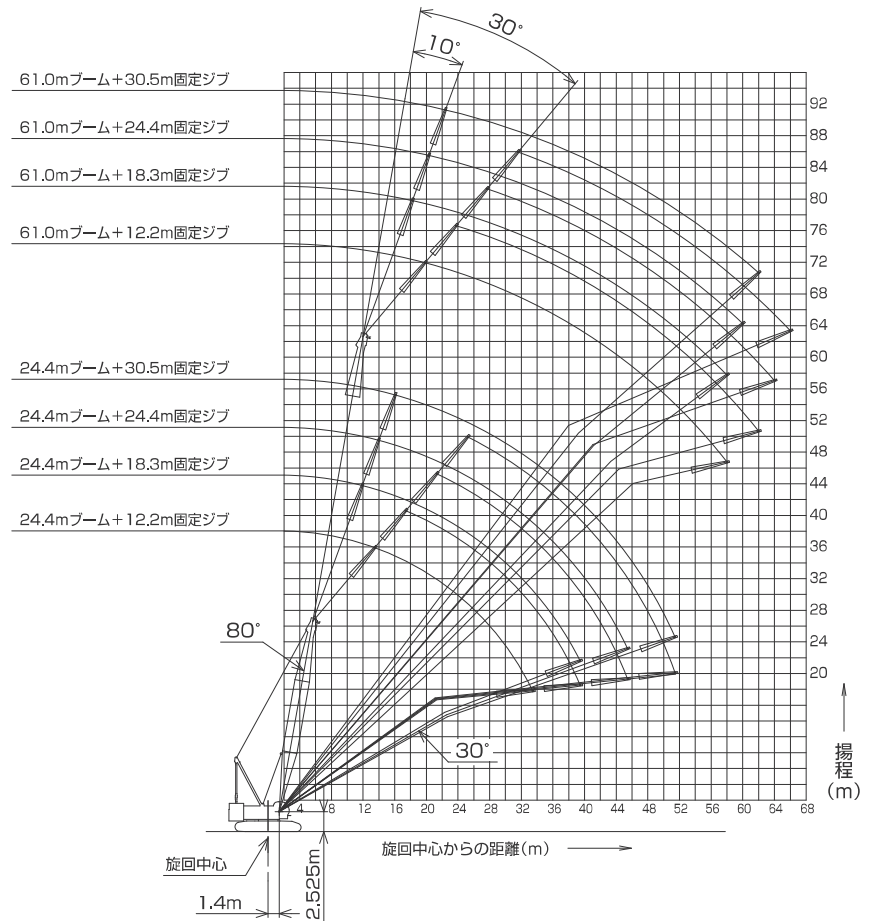

▶定格総荷重

- 定格総荷重とは、水平堅土上における転倒荷重の78%以内で、フックブロック、玉掛用ワイヤロープ等のつり具の質量を含んだ値です。
- 作業半径とはクレーン旋回中心よりつり上荷重の重心までの水平距離を意味します。
- 実際につり上げ得る荷重は定格総荷重から（フック＋玉掛用ワイヤロープ等のつり具）の質量を差し引いた値になります。
- 定格総荷重をつる場合にも風の影響、地盤の状態、作業速度その他安全作業に有害な状況がある時はオペレータは荷重の軽減、作業速度を遅くするなど状況に応じた判断をする責任があります。
- 表中の空欄の個所では作業を行うことができません。
- クレーン作業中には必ずガントリを最高位置に立ててください。

- すべてのboom (jib) 長さにおける中間boom (jib) の構成は取扱説明書の指示を厳守してください。
- 主boomに補助シーブを取り付けたままで主フックを使用する場合の定格総荷重は、主boom定格総荷重から、一律0.8t差し引いた値となります。ただし最小定格総荷重は2.0tとします。
- 補助シーブを装着できる主boom長さは、15.2m (50) ~ 61.0m (200) です。
- 補助シーブを装着できるロングboom長さは61.0m (200) ~ 76.2m (250) です。
- ジブを装着できる主boom長さは、24.4m (80) ~ 61.0m (200) です。

△ 操作ミスなどによるつり荷の落下を防ぐため、クレーン作業では自由降下（フリーフォール）作業は行わないでください。

● 巻上げロープ巻掛本数に対する最大巻上荷重とフックの質量

フック 呼称	最大巻上荷重(t)										フック 質量
	1本掛	2本掛	3本掛	4本掛	5本掛	6本掛	7本掛	8本掛	9本掛	10本掛	
120t	-	-	-	48.0	60.0	72.0	84.0	96.0	108.0	120.0	1.70t
70t	-	24.0	36.0	48.0	60.0	70.0	-	-	-	-	1.20t
35t	-	24.0	35.0	-	-	-	-	-	-	-	0.90t
ボールフック	12.0	-	-	-	-	-	-	-	-	-	0.45t

【カウンタウエイト減量時】

- 自立可能な最長boom長さは、カウンタウエイト段数5段（最上段から1段減量）で、61.0mです。
- カウンタウエイト減量時、ジブ付仕様の設定はありません。
- 補助シーブを装着できる主boom長さは、カウンタウエイト段数5段（最上段から1段減量）で15.2m~61.0mです。

▶主ブーム定格総荷重表

(単位:t)

ブーム長さ 作業半径(m)	15.2	18.3	21.3	24.4	27.4	30.5	33.5	36.6	39.6	42.7	45.7	48.8	51.8	54.9	57.9	61.0	ブーム長さ 作業半径(m)
4.5	120.0/4.5m																4.5
5.0	120.0	108.0/5.1m	96.0/5.6m														5.0
6.0	100.0	99.8	94.9	84.0/6.1m	74.6/6.7m												6.0
7.0	85.7	85.5	85.3	81.5	73.7	66.4/7.2m	59.4/7.7m										7.0
8.0	73.7	73.6	73.5	73.5	71.3	64.7	58.9	53.6/8.2m	48.0/8.8m								8.0
9.0	61.5	61.3	61.2	61.1	61.0	60.9	57.2	52.5	48.0	43.5/9.3m	39.6/9.8m						9.0
10.0	52.6	52.5	52.3	52.2	52.1	52.0	52.0	51.2	46.8	42.8	39.5	36.0/10.4m	32.1/10.9m	29.4/11.4m			10.0
12.0	40.6	40.5	40.3	40.2	40.0	40.0	39.9	39.7	39.7	39.5	37.8	34.7	31.4	29.0	26.9	24.0/12.5m	12.0
14.0	33.0	32.8	32.6	32.5	32.3	32.3	32.2	32.0	31.9	31.8	31.6	31.6	30.1	27.9	25.9	23.5	14.0
16.0	29.1/14.9m	27.5	27.3	27.2	26.9	26.9	26.8	26.6	26.5	26.4	26.2	26.1	26.0	25.8	24.9	22.8	16.0
18.0		24.5/17.5m	23.3	23.2	23.0	22.9	22.8	22.6	22.5	22.4	22.2	22.1	22.0	21.8	21.6	21.4	18.0
20.0			20.3	20.2	20.0	19.9	19.8	19.5	19.5	19.3	19.1	19.1	18.9	18.7	18.6	18.5	20.0
22.0			20.2/20.1m	17.8	17.6	17.5	17.4	17.1	17.1	16.9	16.7	16.6	16.5	16.3	16.1	16.0	22.0
24.0				17.1/22.8m	15.6	15.5	15.4	15.2	15.1	14.9	14.7	14.7	14.5	14.3	14.1	14.1	24.0
26.0					14.5/25.4m	13.9	13.8	13.6	13.5	13.3	13.1	13.0	12.9	12.7	12.5	12.4	26.0
28.0						12.6	12.5	12.2	12.1	12.0	11.7	11.7	11.5	11.3	11.1	11.0	28.0
30.0							11.3	11.1	11.0	10.8	10.6	10.5	10.3	10.1	10.0	9.9	30.0
32.0							11.0/30.7m	10.1	10.0	9.8	9.6	9.5	9.3	9.1	9.0	8.9	32.0
34.0								9.5/33.3m	9.1	8.9	8.7	8.6	8.5	8.2	8.1	8.0	34.0
36.0									8.4	8.2	8.0	7.9	7.7	7.5	7.3	7.2	36.0
38.0										7.5	7.3	7.2	7.0	6.8	6.6	6.5	38.0
40.0										7.4/38.6m	6.7	6.6	6.4	6.2	6.0	5.9	40.0
42.0											6.4/41.2m	6.1	5.9	5.7	5.5	5.4	42.0
44.0												5.6/43.9m	5.4	5.2	5.0	4.9	44.0
46.0													5.0	4.7	4.6	4.4	46.0
48.0													4.9/46.5m	4.3	4.1	3.9	48.0
50.0														4.1/49.2m	3.7	3.5	50.0
52.0															3.3/51.8m	3.1	52.0
54.0																2.7	54.0
56.0																2.7/54.4m	56.0

※表中の太線で囲まれた部分は、ブーム等の強度によって定められた値です。

▶補助シーブ定格総荷重表 (120tフック装着)

(単位:t)

ブーム長さ 作業半径(m)	15.2	18.3	21.3	24.4	27.4	30.5	33.5	36.6	39.6	42.7	45.7	48.8	51.8	54.9	57.9	61.0	ブーム長さ 作業半径(m)
5.0	12.0/5.3m	12.0/5.8m															5.0
6.0	12.0	12.0	12.0/6.3m	12.0/6.9m													6.0
7.0	12.0	12.0	12.0	12.0	12.0/7.4m	12.0/7.9m											7.0
8.0	12.0	12.0	12.0	12.0	12.0	12.0	12.0/8.4m										8.0
9.0	12.0	12.0	12.0	12.0	12.0	12.0	12.0	12.0/9.0m	12.0/9.5m								9.0
10.0	12.0	12.0	12.0	12.0	12.0	12.0	12.0	12.0	12.0	12.0	12.0/10.6m	12.0/11.1m	12.0/11.6m				10.0
12.0	12.0	12.0	12.0	12.0	12.0	12.0	12.0	12.0	12.0	12.0	12.0	12.0	12.0	12.0/12.2m	12.0/12.7m	12.0/13.2m	12.0
14.0	12.0	12.0	12.0	12.0	12.0	12.0	12.0	12.0	12.0	12.0	12.0	12.0	12.0	12.0	12.0	12.0	14.0
16.0	12.0	12.0	12.0	12.0	12.0	12.0	12.0	12.0	12.0	12.0	12.0	12.0	12.0	12.0	12.0	12.0	16.0
18.0	12.0/16.2m	12.0	12.0	12.0	12.0	12.0	12.0	12.0	12.0	12.0	12.0	12.0	12.0	12.0	12.0	12.0	18.0
20.0		12.0/18.8m	12.0	12.0	12.0	12.0	12.0	12.0	12.0	12.0	12.0	12.0	12.0	12.0	12.0	12.0	20.0
22.0			12.0/21.5m	12.0	12.0	12.0	12.0	12.0	12.0	12.0	12.0	12.0	12.0	12.0	12.0	12.0	22.0
24.0				12.0	12.0	12.0	12.0	12.0	12.0	12.0	12.0	12.0	12.0	12.0	12.0	12.0	24.0
26.0				12.0/24.1m	12.0	11.9	11.8	11.6	11.5	11.3	11.1	11.0	10.9	10.7	10.5	10.4	26.0
28.0					11.5/26.7m	10.6	10.5	10.2	10.1	10.0	9.7	9.7	9.5	9.3	9.1	9.0	28.0
30.0						9.7/29.4m	9.3	9.1	9.0	8.8	8.6	8.5	8.3	8.1	8.0	7.9	30.0
32.0							8.4	8.1	8.0	7.8	7.6	7.5	7.3	7.1	7.0	6.9	32.0
34.0								7.2	7.1	6.9	6.7	6.6	6.5	6.2	6.1	6.0	34.0
36.0								6.9/34.7m	6.4	6.2	6.0	5.9	5.7	5.5	5.3	5.2	36.0
38.0									5.9/37.3m	5.5	5.3	5.2	5.0	4.8	4.6	4.5	38.0
40.0										5.2/39.9m	4.7	4.6	4.4	4.2	4.0	3.9	40.0
42.0											4.2	4.1	3.9	3.7	3.5	3.4	42.0
44.0											4.1/42.6m	3.6	3.4	3.2	3.0	2.9	44.0
46.0												3.3/45.2m	3.0	2.7	2.6	2.4	46.0
48.0													2.6/47.9m	2.3	2.1		48.0
50.0														2.0			50.0

※表中の太線で囲まれた部分は、ブーム等の強度によって定められた値です。

▶ 補助シーブ定格総荷重表 (70tフック装着)

(単位:t)

ブーム長さ 作業半径(m)	15.2	18.3	21.3	24.4	27.4	30.5	33.5	36.6	39.6	42.7	45.7	48.8	51.8	54.9	57.9	61.0	ブーム長さ 作業半径(m)
5.0	12.0/5.3m	12.0/5.8m															5.0
6.0	12.0	12.0	12.0/6.3m	12.0/6.9m													6.0
7.0	12.0	12.0	12.0	12.0	12.0/7.4m	12.0/7.9m											7.0
8.0	12.0	12.0	12.0	12.0	12.0	12.0	12.0/8.4m										8.0
9.0	12.0	12.0	12.0	12.0	12.0	12.0	12.0	12.0/9.0m	12.0/9.5m								9.0
10.0	12.0	12.0	12.0	12.0	12.0	12.0	12.0	12.0	12.0	12.0	12.0/10.6m	12.0/11.1m	12.0/11.6m				10.0
12.0	12.0	12.0	12.0	12.0	12.0	12.0	12.0	12.0	12.0	12.0	12.0	12.0	12.0	12.0/12.2m	12.0/12.7m	12.0/13.2m	12.0
14.0	12.0	12.0	12.0	12.0	12.0	12.0	12.0	12.0	12.0	12.0	12.0	12.0	12.0	12.0	12.0	12.0	14.0
16.0	12.0	12.0	12.0	12.0	12.0	12.0	12.0	12.0	12.0	12.0	12.0	12.0	12.0	12.0	12.0	12.0	16.0
18.0	12.0/16.2m	12.0	12.0	12.0	12.0	12.0	12.0	12.0	12.0	12.0	12.0	12.0	12.0	12.0	12.0	12.0	18.0
20.0		12.0/18.8m	12.0	12.0	12.0	12.0	12.0	12.0	12.0	12.0	12.0	12.0	12.0	12.0	12.0	12.0	20.0
22.0			12.0/21.5m	12.0	12.0	12.0	12.0	12.0	12.0	12.0	12.0	12.0	12.0	12.0	12.0	12.0	22.0
24.0				12.0	12.0	12.0	12.0	12.0	12.0	12.0	12.0	12.0	12.0	12.0	12.0	12.0	24.0
26.0				12.0/24.1m	12.0	12.0	12.0	12.0	12.0	12.0	11.8	11.6	11.5	11.4	11.2	11.0	26.0
28.0					12.0/26.7m	11.1	11.0	10.7	10.6	10.5	10.2	10.2	10.0	9.8	9.6	9.5	28.0
30.0						10.2/29.4m	9.8	9.6	9.5	9.3	9.1	9.0	8.8	8.6	8.5	8.4	30.0
32.0							8.9	8.6	8.5	8.3	8.1	8.0	7.8	7.6	7.5	7.4	32.0
34.0								7.7	7.6	7.4	7.2	7.1	7.0	6.7	6.6	6.5	34.0
36.0								7.4/34.7m	6.9	6.7	6.5	6.4	6.2	6.0	5.8	5.7	36.0
38.0									6.4/37.3m	6.0	5.8	5.7	5.5	5.3	5.1	5.0	38.0
40.0										5.7/39.9m	5.2	5.1	4.9	4.7	4.5	4.4	40.0
42.0											4.7	4.6	4.4	4.2	4.0	3.9	42.0
44.0											4.6/42.6m	4.1	3.9	3.7	3.5	3.4	44.0
46.0												3.8/45.2m	3.5	3.2	3.1	2.9	46.0
48.0													3.1/47.9m	2.8	2.6	2.4	48.0
50.0														2.5	2.2	2.0	50.0
52.0														2.4/50.5m			52.0

※表中の太線で囲まれた部分は、ブーム等の強度によって定められた値です。

▶ 補助シーブ定格総荷重表 (35tフック装着)

(単位:t)

ブーム長さ 作業半径(m)	15.2	18.3	21.3	24.4	27.4	30.5	33.5	36.6	39.6	42.7	45.7	48.8	51.8	54.9	57.9	61.0	ブーム長さ 作業半径(m)
5.0	12.0/5.3m	12.0/5.8m															5.0
6.0	12.0	12.0	12.0/6.3m	12.0/6.9m													6.0
7.0	12.0	12.0	12.0	12.0	12.0/7.4m	12.0/7.9m											7.0
8.0	12.0	12.0	12.0	12.0	12.0	12.0	12.0/8.4m										8.0
9.0	12.0	12.0	12.0	12.0	12.0	12.0	12.0	12.0/9.0m	12.0/9.5m								9.0
10.0	12.0	12.0	12.0	12.0	12.0	12.0	12.0	12.0	12.0	12.0	12.0/10.6m	12.0/11.1m	12.0/11.6m				10.0
12.0	12.0	12.0	12.0	12.0	12.0	12.0	12.0	12.0	12.0	12.0	12.0	12.0	12.0	12.0/12.2m	12.0/12.7m	12.0/13.2m	12.0
14.0	12.0	12.0	12.0	12.0	12.0	12.0	12.0	12.0	12.0	12.0	12.0	12.0	12.0	12.0	12.0	12.0	14.0
16.0	12.0	12.0	12.0	12.0	12.0	12.0	12.0	12.0	12.0	12.0	12.0	12.0	12.0	12.0	12.0	12.0	16.0
18.0	12.0/16.2m	12.0	12.0	12.0	12.0	12.0	12.0	12.0	12.0	12.0	12.0	12.0	12.0	12.0	12.0	12.0	18.0
20.0		12.0/18.8m	12.0	12.0	12.0	12.0	12.0	12.0	12.0	12.0	12.0	12.0	12.0	12.0	12.0	12.0	20.0
22.0			12.0/21.5m	12.0	12.0	12.0	12.0	12.0	12.0	12.0	12.0	12.0	12.0	12.0	12.0	12.0	22.0
24.0				12.0	12.0	12.0	12.0	12.0	12.0	12.0	12.0	12.0	12.0	12.0	12.0	12.0	24.0
26.0				12.0/24.1m	12.0	12.0	12.0	12.0	12.0	12.0	11.9	11.8	11.7	11.5	11.3	11.2	26.0
28.0					12.0/26.7m	11.4	11.3	11.0	10.9	10.8	10.5	10.5	10.3	10.1	9.9	9.8	28.0
30.0						10.5/29.4m	10.1	9.9	9.8	9.6	9.4	9.3	9.1	8.9	8.8	8.7	30.0
32.0							9.2	8.9	8.8	8.6	8.4	8.3	8.1	7.9	7.8	7.7	32.0
34.0								8.0	7.9	7.7	7.5	7.4	7.3	7.0	6.9	6.8	34.0
36.0								7.7/34.7m	7.2	7.0	6.8	6.7	6.5	6.3	6.1	6.0	36.0
38.0									6.7/37.3m	6.3	6.1	6.0	5.8	5.6	5.4	5.3	38.0
40.0										6.0/39.9m	5.5	5.4	5.2	5.0	4.8	4.7	40.0
42.0											5.0	4.9	4.7	4.5	4.3	4.2	42.0
44.0											4.9/42.6m	4.4	4.2	4.0	3.8	3.7	44.0
46.0												4.1/45.2m	3.8	3.5	3.4	3.2	46.0
48.0													3.4/47.9m	3.1	2.9	2.7	48.0
50.0														2.8	2.5	2.3	50.0
52.0														2.7/50.5m	2.1		52.0

※表中の太線で囲まれた部分は、ブーム等の強度によって定められた値です。

▶ 補助シーブ定格総荷重表 (主ブームにフックなし)

(単位:t)

ブーム長さ (m) 作業半径(m)	15.2	18.3	21.3	24.4	27.4	30.5	33.5	36.6	39.6	42.7	45.7	48.8	51.8	54.9	57.9	61.0	ブーム長さ (m) 作業半径(m)			
5.0	12.0/5.3m	12.0/5.8m															5.0			
6.0	12.0	12.0	12.0/6.3m	12.0/6.9m													6.0			
7.0	12.0	12.0	12.0	12.0	12.0/7.4m	12.0/7.9m											7.0			
8.0	12.0	12.0	12.0	12.0	12.0	12.0	12.0/8.4m										8.0			
9.0	12.0	12.0	12.0	12.0	12.0	12.0	12.0	12.0	12.0/9.5m								9.0			
10.0	12.0	12.0	12.0	12.0	12.0	12.0	12.0	12.0	12.0	12.0	12.0/10.6m	12.0/11.1m	12.0/11.6m				10.0			
12.0	12.0	12.0	12.0	12.0	12.0	12.0	12.0	12.0	12.0	12.0	12.0	12.0	12.0	12.0/12.2m	12.0/12.7m	12.0/13.2m	12.0			
14.0	12.0	12.0	12.0	12.0	12.0	12.0	12.0	12.0	12.0	12.0	12.0	12.0	12.0	12.0	12.0	12.0	14.0			
16.0	12.0	12.0	12.0	12.0	12.0	12.0	12.0	12.0	12.0	12.0	12.0	12.0	12.0	12.0	12.0	12.0	16.0			
18.0	12.0/16.2m	12.0	12.0	12.0	12.0	12.0	12.0	12.0	12.0	12.0	12.0	12.0	12.0	12.0	12.0	12.0	18.0			
20.0		12.0/18.8m	12.0	12.0	12.0	12.0	12.0	12.0	12.0	12.0	12.0	12.0	12.0	12.0	12.0	12.0	20.0			
22.0			12.0/21.5m	12.0	12.0	12.0	12.0	12.0	12.0	12.0	12.0	12.0	12.0	12.0	12.0	12.0	22.0			
24.0				12.0	12.0	12.0	12.0	12.0	12.0	12.0	12.0	12.0	12.0	12.0	12.0	12.0	24.0			
26.0				12.0/24.1m	12.0	12.0	12.0	12.0	12.0	12.0	12.0	12.0	12.0	12.0	12.0	12.0	26.0			
28.0					12.0/26.7m	12.0	12.0	11.9	11.8	11.7	11.4	11.4	11.2	11.0	10.8	10.7	28.0			
30.0						12.0/29.4m	11.0	10.8	10.7	10.5	10.3	10.2	10.0	9.8	9.7	9.6	30.0			
32.0							10.1	9.8	9.7	9.5	9.3	9.2	9.0	8.8	8.7	8.6	32.0			
34.0								8.9	8.8	8.6	8.4	8.3	8.2	7.9	7.8	7.7	34.0			
36.0									8.6/34.7m	8.1	7.9	7.7	7.6	7.4	7.2	7.0	36.0			
38.0										7.6/37.3m	7.2	7.0	6.9	6.7	6.5	6.3	38.0			
40.0											6.9/39.9m	6.4	6.3	6.1	5.9	5.7	40.0			
42.0												5.9	5.8	5.6	5.4	5.1	42.0			
44.0													5.8/42.6m	5.3	5.1	4.9	44.0			
46.0														5.0/45.2m	4.7	4.4	46.0			
48.0															4.3/47.9m	4.0	3.8	48.0		
50.0																3.7	3.4	50.0		
52.0																	3.6/50.5m	3.0	52.0	
54.0																		2.7/53.1m	2.4	54.0
56.0																			2.0/55.8m	56.0

※表中の太線で囲まれた部分は、ブーム等の強度によって定められた値です。

▶ ロング主ブーム定格総荷重表

(単位:t)

ブーム長さ (m) 作業半径(m)	61.0	64.0	67.1	70.1	73.2	76.2	79.2	ブーム長さ (m) 作業半径(m)
12.0	24.0/12.3m	24.0/12.8m	24.0/13.3m	24.0/13.9m				12.0
14.0	24.0	24.0	24.0	24.0	22.1/14.4m	18.7/14.9m	16.3/15.4m	14.0
16.0	24.0	24.0	24.0	24.0	20.9	17.9	15.9	16.0
18.0	22.8	22.6	22.5	22.5	19.5	16.7	14.8	18.0
20.0	19.7	19.5	19.5	19.4	18.3	15.7	13.9	20.0
22.0	17.3	17.1	17.0	17.0	16.9	14.8	13.1	22.0
24.0	15.3	15.1	15.0	15.0	14.9	14.0	12.3	24.0
26.0	13.7	13.5	13.4	13.4	13.3	13.1	11.7	26.0
28.0	12.3	12.1	12.0	12.0	11.9	11.7	11.2	28.0
30.0	11.1	10.9	10.8	10.8	10.7	10.6	10.5	30.0
32.0	10.1	9.9	9.8	9.8	9.7	9.5	9.5	32.0
34.0	9.2	9.0	8.9	8.9	8.8	8.7	8.6	34.0
36.0	8.4	8.3	8.2	8.1	8.0	7.9	7.8	36.0
38.0	7.8	7.6	7.5	7.5	7.4	7.2	7.2	38.0
40.0	7.2	7.0	6.9	6.8	6.7	6.6	6.5	40.0
42.0	6.6	6.4	6.3	6.3	6.2	6.0	6.0	42.0
44.0	6.1	5.9	5.8	5.8	5.7	5.5	5.5	44.0
46.0	5.7	5.5	5.4	5.3	5.2	5.1	5.0	46.0
48.0	5.3	5.1	5.0	4.9	4.8	4.7	4.6	48.0
50.0	4.9	4.7	4.6	4.6	4.5	4.3	4.3	50.0
52.0	4.6	4.4	4.3	4.2	4.1	4.0	3.9	52.0
54.0	4.3	4.1	3.9	3.9	3.8	3.6	3.5	54.0
56.0	4.2/54.4m	3.8	3.7	3.6	3.5	3.3	3.2	56.0
58.0		3.6/57.0m	3.4	3.3	3.2	2.9	2.9	58.0
60.0			3.1/59.7m	3.0	2.9	2.6	2.6	60.0
62.0				2.8	2.6	2.4	2.3	62.0
64.0					2.7/62.3m	2.4	2.1	64.0
66.0						2.2/64.9m		66.0

※表中の太線で囲まれた部分は、ブーム等の強度によって定められた値です。

▶ ロング補助シーブ定格総荷重表 (35tフック装着)

(単位:t)

ブーム長さ 作業半径(m)	61.0	64.0	67.1	70.1	73.2	76.2	ブーム長さ 作業半径(m)
12.0	12.0/12.9m	12.0/13.4m					12.0
14.0	12.0	12.0	12.0	12.0/14.5m	12.0/15.0m	12.0/15.5m	14.0
16.0	12.0	12.0	12.0	12.0	12.0	12.0	16.0
18.0	12.0	12.0	12.0	12.0	12.0	12.0	18.0
20.0	12.0	12.0	12.0	12.0	12.0	12.0	20.0
22.0	12.0	12.0	12.0	12.0	12.0	12.0	22.0
24.0	12.0	12.0	12.0	12.0	12.0	12.0	24.0
26.0	12.0	12.0	12.0	12.0	12.0	11.9	26.0
28.0	11.1	10.9	10.8	10.8	10.7	10.5	28.0
30.0	9.9	9.7	9.6	9.6	9.5	9.4	30.0
32.0	8.9	8.7	8.6	8.6	8.5	8.3	32.0
34.0	8.0	7.8	7.7	7.7	7.6	7.5	34.0
36.0	7.2	7.1	7.0	6.9	6.8	6.7	36.0
38.0	6.6	6.4	6.3	6.3	6.2	6.0	38.0
40.0	6.0	5.8	5.7	5.6	5.5	5.4	40.0
42.0	5.4	5.2	5.1	5.1	5.0	4.8	42.0
44.0	4.9	4.7	4.6	4.6	4.5	4.3	44.0
46.0	4.5	4.3	4.2	4.1	4.0	3.9	46.0
48.0	4.1	3.9	3.8	3.7	3.6	3.5	48.0
50.0	3.7	3.5	3.4	3.4	3.3	3.1	50.0
52.0	3.4	3.2	3.1	3.0	2.9	2.8	52.0
54.0	3.1	2.9	2.7	2.7	2.6	2.4	54.0
56.0	2.9/55.1m	2.6	2.5	2.4	2.3	2.1	56.0
58.0		2.3/57.8m	2.2	2.1	2.0		58.0

※表中の太線で囲まれた部分は、ブーム等の強度によって定められた値です。

▶ ロング補助シーブ定格総荷重表 (主ブームにフックなし)

(単位:t)

ブーム長さ 作業半径(m)	61.0	64.0	67.1	70.1	73.2	76.2	ブーム長さ 作業半径(m)
12.0	12.0/12.9m	12.0/13.4m					12.0
14.0	12.0	12.0	12.0	12.0/14.5m	12.0/15.0m	12.0/15.5m	14.0
16.0	12.0	12.0	12.0	12.0	12.0	12.0	16.0
18.0	12.0	12.0	12.0	12.0	12.0	12.0	18.0
20.0	12.0	12.0	12.0	12.0	12.0	12.0	20.0
22.0	12.0	12.0	12.0	12.0	12.0	12.0	22.0
24.0	12.0	12.0	12.0	12.0	12.0	12.0	24.0
26.0	12.0	12.0	12.0	12.0	12.0	12.0	26.0
28.0	12.0	11.8	11.7	11.7	11.6	11.4	28.0
30.0	10.8	10.6	10.5	10.5	10.4	10.3	30.0
32.0	9.8	9.6	9.5	9.5	9.4	9.2	32.0
34.0	8.9	8.7	8.6	8.6	8.5	8.4	34.0
36.0	8.1	8.0	7.9	7.8	7.7	7.6	36.0
38.0	7.5	7.3	7.2	7.2	7.1	6.9	38.0
40.0	6.9	6.7	6.6	6.5	6.4	6.3	40.0
42.0	6.3	6.1	6.0	6.0	5.9	5.7	42.0
44.0	5.8	5.6	5.5	5.5	5.4	5.2	44.0
46.0	5.4	5.2	5.1	5.0	4.9	4.8	46.0
48.0	5.0	4.8	4.7	4.6	4.5	4.4	48.0
50.0	4.6	4.4	4.3	4.3	4.2	4.0	50.0
52.0	4.3	4.1	4.0	3.9	3.8	3.7	52.0
54.0	4.0	3.8	3.6	3.6	3.5	3.3	54.0
56.0	3.7/55.1m	3.5	3.4	3.3	3.2	3.0	56.0
58.0		3.2/57.8m	3.1	3.0	2.9	2.6	58.0
60.0			2.8	2.7	2.6	2.3	60.0
62.0			2.7/60.4m	2.5	2.3	2.1	62.0
64.0				2.4/63.0m	2.1		64.0
66.0							66.0

※表中の太線で囲まれた部分は、ブーム等の強度によって定められた値です。

▶ジブ定格総荷重表(主フックなし/ジブオフセット角度10°) (単位:t)

ブーム長さ(m) ジブ長さ(m) 作業半径(m)	24.4			27.4			30.5			33.5			ブーム長さ(m) ジブ長さ(m) 作業半径(m)
	18.3	24.4	30.5	18.3	24.4	30.5	18.3	24.4	30.5	18.3	24.4	30.5	
12.0	12.0/12.2m			12.0/12.8m			12.0/13.3m			12.0/13.8m			12.0
14.0	12.0	8.0/14.3m		12.0	8.0/14.9m		12.0	8.0/15.4m		12.0	8.0/15.9m		14.0
16.0	12.0	8.0	4.0/16.4m	12.0	8.0	4.0/16.9m	12.0	8.0	4.0/17.5m	12.0	8.0		16.0
18.0	12.0	8.0	4.0	12.0	8.0	4.0	12.0	8.0	4.0	12.0	8.0	4.0	18.0
20.0	12.0	8.0	4.0	12.0	8.0	4.0	12.0	8.0	4.0	12.0	8.0	4.0	20.0
22.0	12.0	7.6	4.0	12.0	7.8	4.0	12.0	8.0	4.0	12.0	8.0	4.0	22.0
24.0	12.0	7.3	4.0	12.0	7.4	4.0	12.0	7.6	4.0	12.0	7.8	4.0	24.0
26.0	12.0	7.0	4.0	12.0	7.1	4.0	12.0	7.3	4.0	12.0	7.5	4.0	26.0
28.0	11.8	6.7	3.9	12.0	6.9	4.0	12.0	7.0	4.0	12.0	7.2	4.0	28.0
30.0	11.0	6.4	3.7	11.7	6.6	3.8	11.9	6.8	3.9	11.7	6.9	4.0	30.0
32.0	10.3	6.2	3.5	11.0	6.4	3.6	10.9	6.5	3.7	10.7	6.7	3.8	32.0
34.0	9.7	6.0	3.4	10.1	6.2	3.5	10.0	6.3	3.6	9.8	6.5	3.7	34.0
36.0	9.2	5.8	3.2	9.4	6.0	3.3	9.2	6.1	3.4	9.0	6.3	3.5	36.0
38.0	8.7	5.6	3.1	8.7	5.8	3.2	8.5	5.9	3.3	8.3	6.1	3.4	38.0
40.0	8.3	5.5	3.0	8.1	5.6	3.1	7.9	5.8	3.2	7.7	5.9	3.3	40.0
42.0		5.3	2.9	7.5	5.5	3.0	7.3	5.6	3.1	7.2	5.8	3.2	42.0
44.0		5.2	2.8		5.4	2.9	6.9	5.5	3.0	6.7	5.6	3.1	44.0
46.0			2.7		5.2	2.8		5.4	2.9	6.2	5.5	3.0	46.0
48.0			2.6		5.2	2.7		5.3	2.8	5.8	5.4	2.9	48.0
50.0			2.6			2.6		5.2	2.7		5.3	2.8	50.0
52.0						2.6			2.6		5.2	2.7	52.0
54.0									2.6			2.7	54.0
56.0									2.5			2.6	56.0
58.0												2.5	58.0

※表中の太線で囲まれた部分は、ブーム等の強度によって定められた値です。

ブーム長さ(m) ジブ長さ(m) 作業半径(m)	36.6			39.6			42.7			ブーム長さ(m) ジブ長さ(m) 作業半径(m)
	18.3	24.4	30.5	18.3	24.4	30.5	18.3	24.4	30.5	
14.0	12.0/14.4m			12.0/14.9m			12.0/15.4m			14.0
16.0	12.0	8.0/16.4m		12.0	8.0/17.0m		12.0	8.0/17.5m		16.0
18.0	12.0	8.0	4.0/18.5m	12.0	8.0	4.0/19.1m	12.0	8.0	4.0/19.6m	18.0
20.0	12.0	8.0	4.0	12.0	8.0	4.0	12.0	8.0	4.0	20.0
22.0	12.0	8.0	4.0	12.0	8.0	4.0	12.0	8.0	4.0	22.0
24.0	12.0	7.9	4.0	12.0	8.0	4.0	12.0	8.0	4.0	24.0
26.0	12.0	7.6	4.0	12.0	7.8	4.0	12.0	7.9	4.0	26.0
28.0	12.0	7.3	4.0	12.0	7.5	4.0	12.0	7.6	4.0	28.0
30.0	11.5	7.1	4.0	11.4	7.2	4.0	11.2	7.4	4.0	30.0
32.0	10.5	6.9	3.9	10.3	7.0	4.0	10.2	7.1	4.0	32.0
34.0	9.6	6.6	3.8	9.4	6.8	3.9	9.3	6.9	4.0	34.0
36.0	8.8	6.4	3.6	8.7	6.6	3.7	8.5	6.7	3.8	36.0
38.0	8.1	6.2	3.5	8.0	6.4	3.6	7.8	6.5	3.7	38.0
40.0	7.5	6.1	3.4	7.3	6.2	3.5	7.2	6.3	3.6	40.0
42.0	6.9	5.9	3.3	6.8	6.0	3.4	6.6	6.2	3.4	42.0
44.0	6.4	5.8	3.2	6.3	5.9	3.2	6.1	6.0	3.3	44.0
46.0	6.0	5.6	3.1	5.8	5.8	3.1	5.7	5.9	3.2	46.0
48.0	5.6	5.5	3.0	5.4	5.6	3.0	5.2	5.5	3.1	48.0
50.0	5.2	5.4	2.9	5.1	5.3	3.0	4.9	5.1	3.0	50.0
52.0		5.1	2.8	4.7	4.9	2.9	4.5	4.8	3.0	52.0
54.0		4.7	2.7		4.6	2.8	4.2	4.4	2.9	54.0
56.0		4.5	2.7		4.3	2.7	3.9	4.1	2.8	56.0
58.0			2.6		4.0	2.7		3.9	2.7	58.0
60.0			2.5			2.6		3.6	2.7	60.0
62.0						2.6			2.6	62.0
64.0						2.5			2.6	64.0
66.0									2.5	66.0

※表中の太線で囲まれた部分は、ブーム等の強度によって定められた値です。

●クローラークレーン●

ブーム長さ(m) ジブ長さ (m) 作業半径(m)	45.7			48.8			51.8			ブーム長さ(m) ジブ長さ (m) 作業半径(m)
	18.3	24.4	30.5	18.3	24.4	30.5	18.3	24.4	30.5	
14.0	12.0/15.9m									14.0
16.0	12.0			12.0/16.5m			12.0/17.0m			16.0
18.0	12.0	8.0		12.0	8.0/18.6m		12.0	8.0/19.1m		18.0
20.0	12.0	8.0	4.0/20.1m	12.0	8.0	4.0/20.6m	12.0	8.0	4.0/21.2m	20.0
22.0	12.0	8.0	4.0	12.0	8.0	4.0	12.0	8.0	4.0	22.0
24.0	12.0	8.0	4.0	12.0	8.0	4.0	12.0	8.0	4.0	24.0
26.0	12.0	8.0	4.0	12.0	8.0	4.0	12.0	8.0	4.0	26.0
28.0	12.0	7.8	4.0	12.0	7.9	4.0	11.9	8.0	4.0	28.0
30.0	11.0	7.5	4.0	10.9	7.6	4.0	10.7	7.8	4.0	30.0
32.0	10.0	7.3	4.0	9.8	7.4	4.0	9.7	7.5	4.0	32.0
34.0	9.1	7.1	4.0	8.9	7.2	4.0	8.8	7.3	4.0	34.0
36.0	8.3	6.8	3.9	8.1	7.0	4.0	8.0	7.1	4.0	36.0
38.0	7.6	6.7	3.8	7.4	6.8	3.8	7.3	6.9	3.9	38.0
40.0	7.0	6.5	3.6	6.8	6.6	3.7	6.6	6.7	3.8	40.0
42.0	6.4	6.3	3.5	6.2	6.4	3.6	6.1	6.4	3.7	42.0
44.0	5.9	6.2	3.4	5.7	6.0	3.5	5.6	5.9	3.6	44.0
46.0	5.4	5.7	3.3	5.3	5.6	3.4	5.1	5.4	3.4	46.0
48.0	5.0	5.3	3.2	4.9	5.1	3.3	4.7	5.0	3.4	48.0
50.0	4.6	4.9	3.1	4.5	4.8	3.2	4.3	4.6	3.3	50.0
52.0	4.3	4.5	3.0	4.1	4.4	3.1	4.0	4.2	3.2	52.0
54.0	4.0	4.2	2.9	3.8	4.1	3.0	3.6	3.9	3.1	54.0
56.0	3.7	3.9	2.9	3.5	3.8	2.9	3.3	3.6	3.0	56.0
58.0	3.4	3.6	2.8	3.2	3.5	2.9	2.9	3.3	2.9	58.0
60.0		3.4	2.7	2.9	3.2	2.8	2.6	3.0	2.9	60.0
62.0		3.1	2.7		2.9	2.7	2.4	2.7	2.8	62.0
64.0		2.9	2.6		2.6	2.7		2.4	2.5	64.0
66.0			2.6		2.4	2.5		2.2	2.3	66.0
68.0			2.5			2.3			2.0	68.0
70.0						2.1				70.0

※表中の太線で囲まれた部分は、ブーム等の強度によって定められた値です。

ブーム長さ(m) ジブ長さ (m) 作業半径(m)	54.9			57.9			61.0			ブーム長さ(m) ジブ長さ (m) 作業半径(m)
	18.3	24.4	30.5	18.3	24.4	30.5	18.3	24.4	30.5	
16.0	12.0/17.5m									16.0
18.0	12.0	8.0/19.6m		12.0/18.1m			12.0/18.6m			18.0
20.0	12.0	8.0	4.0/21.7m	12.0	8.0/20.1m		12.0	8.0/20.7m		20.0
22.0	12.0	8.0	4.0	12.0	8.0	4.0/22.2m	12.0	8.0	4.0/22.8m	22.0
24.0	12.0	8.0	4.0	12.0	8.0	4.0	12.0	8.0	4.0	24.0
26.0	12.0	8.0	4.0	12.0	8.0	4.0	12.0	8.0	4.0	26.0
28.0	11.7	8.0	4.0	11.5	8.0	4.0	11.4	8.0	4.0	28.0
30.0	10.5	7.9	4.0	10.3	8.0	4.0	10.2	8.0	4.0	30.0
32.0	9.5	7.6	4.0	9.3	7.7	4.0	9.1	7.8	4.0	32.0
34.0	8.6	7.4	4.0	8.4	7.5	4.0	8.2	7.6	4.0	34.0
36.0	7.8	7.2	4.0	7.6	7.3	4.0	7.4	7.4	4.0	36.0
38.0	7.1	7.0	4.0	6.9	7.1	4.0	6.7	7.1	4.0	38.0
40.0	6.4	6.8	3.9	6.2	6.6	3.9	6.1	6.4	4.0	40.0
42.0	5.9	6.2	3.7	5.7	6.0	3.8	5.5	5.9	3.9	42.0
44.0	5.4	5.7	3.6	5.2	5.5	3.7	5.0	5.4	3.8	44.0
46.0	4.9	5.2	3.5	4.7	5.0	3.6	4.5	4.9	3.7	46.0
48.0	4.5	4.8	3.4	4.3	4.6	3.5	4.1	4.5	3.6	48.0
50.0	4.1	4.4	3.3	3.9	4.2	3.4	3.6	4.1	3.5	50.0
52.0	3.7	4.0	3.2	3.4	3.9	3.3	3.2	3.6	3.4	52.0
54.0	3.3	3.7	3.2	3.1	3.5	3.2	2.8	3.2	3.3	54.0
56.0	3.0	3.3	3.1	2.7	3.1	3.1	2.5	2.9	3.0	56.0
58.0	2.6	3.0	3.0	2.4	2.8	2.9	2.1	2.5	2.7	58.0
60.0	2.3	2.7	2.8	2.1	2.4	2.6		2.2	2.4	60.0
62.0	2.1	2.4	2.5		2.2	2.3			2.1	62.0
64.0		2.1	2.3			2.0				64.0
66.0			2.0							66.0

※表中の太線で囲まれた部分は、ブーム等の強度によって定められた値です。

▶ジブ定格総荷重表(主フックなし/ジブオフセット角度30°)

(単位:t)

ブーム長さ(m) ジブ長さ (m) 作業半径(m)	24.4				27.4				30.5				33.5				ブーム長さ(m) ジブ長さ (m) 作業半径(m)
	12.2	18.3	24.4	30.5	12.2	18.3	24.4	30.5	12.2	18.3	24.4	30.5	12.2	18.3	24.4	30.5	
12.0	10.0/13.8m																12.0
14.0	10.0				10.0/14.3m				10.0/14.9m				10.0/15.4m				14.0
16.0	10.0	9.0/17.7m			10.0				10.0				10.0				16.0
18.0	10.0	9.0			10.0	9.0/18.3m			10.0	9.0/18.8m			10.0	9.0/19.3m			18.0
20.0	10.0	9.0	6.0/21.7m		10.0	9.0			10.0	9.0			10.0	9.0			20.0
22.0	10.0	9.0	6.0		10.0	9.0	6.0/22.2m		10.0	9.0	6.0/22.7m		10.0	9.0	6.0/23.2m		22.0
24.0	10.0	9.0	6.0	3.0/25.6m	10.0	9.0	6.0		10.0	9.0	6.0		10.0	9.0	6.0		24.0
26.0	10.0	9.0	6.0	3.0	10.0	9.0	6.0	3.0/26.1m	10.0	9.0	6.0	3.0/26.6m	10.0	9.0	6.0	3.0/27.2m	26.0
28.0	10.0	8.7	5.8	3.0	10.0	9.0	5.9	3.0	10.0	9.0	6.0	3.0	10.0	9.0	6.0	3.0	28.0
30.0	10.0	8.3	5.7	3.0	10.0	8.6	5.8	3.0	10.0	8.9	5.8	3.0	10.0	9.0	5.9	3.0	30.0
32.0	10.0	7.9	5.5	3.0	10.0	8.2	5.6	3.0	10.0	8.5	5.7	3.0	10.0	8.7	5.8	3.0	32.0
34.0	10.0	7.6	5.4	2.9	10.0	7.9	5.5	3.0	9.9	8.1	5.6	3.0	9.8	8.4	5.6	3.0	34.0
36.0		7.3	5.3	2.8	9.3	7.6	5.4	2.9	9.1	7.8	5.5	2.9	9.0	8.1	5.5	3.0	36.0
38.0		7.1	5.2	2.7		7.3	5.3	2.8	8.4	7.5	5.4	2.8	8.3	7.8	5.4	2.9	38.0
40.0		6.9	5.1	2.7		7.1	5.2	2.7	7.8	7.3	5.3	2.8	7.6	7.5	5.3	2.8	40.0
42.0			5.0	2.6		6.9	5.1	2.7		7.1	5.2	2.7	7.1	7.3	5.2	2.7	42.0
44.0			4.8	2.6			5.0	2.6		7.0	5.1	2.6		6.9	5.2	2.7	44.0
46.0			4.7	2.5			4.8	2.5		6.5	5.0	2.6		6.4	5.1	2.6	46.0
48.0				2.5			4.7	2.5			4.8	2.5		6.0	5.0	2.6	48.0
50.0				2.4				2.5			4.8	2.5			4.9	2.5	50.0
52.0				2.4				2.4			4.7	2.5			4.8	2.5	52.0
54.0								2.4				2.4			4.7	2.5	54.0
56.0												2.4				2.4	56.0
58.0												2.4				2.4	58.0
60.0																2.4	60.0

※表中の太線で囲まれた部分は、ブーム等の強度によって定められた値です。

ブーム長さ(m) ジブ長さ (m) 作業半径(m)	36.6				39.6				42.7				ブーム長さ(m) ジブ長さ (m) 作業半径(m)
	12.2	18.3	24.4	30.5	12.2	18.3	24.4	30.5	12.2	18.3	24.4	30.5	
14.0	10.0/15.9m												14.0
16.0	10.0				10.0/16.5m				10.0/17.0m				16.0
18.0	10.0	9.0/19.9m			10.0				10.0				18.0
20.0	10.0	9.0			10.0	9.0/20.4m			10.0	9.0/20.9m			20.0
22.0	10.0	9.0	6.0/23.8m		10.0	9.0			10.0	9.0			22.0
24.0	10.0	9.0	6.0		10.0	9.0	6.0/24.3m		10.0	9.0	6.0/24.8m		24.0
26.0	10.0	9.0	6.0	3.0/27.7m	10.0	9.0	6.0		10.0	9.0	6.0		26.0
28.0	10.0	9.0	6.0	3.0	10.0	9.0	6.0	3.0/28.2m	10.0	9.0	6.0	3.0/28.8m	28.0
30.0	10.0	9.0	6.0	3.0	10.0	9.0	6.0	3.0	10.0	9.0	6.0	3.0	30.0
32.0	10.0	9.0	5.8	3.0	10.0	9.0	5.9	3.0	10.0	9.0	5.9	3.0	32.0
34.0	9.6	8.6	5.7	3.0	9.5	8.9	5.8	3.0	9.3	9.0	5.8	3.0	34.0
36.0	8.8	8.3	5.6	3.0	8.7	8.5	5.6	3.0	8.5	8.7	5.7	3.0	36.0
38.0	8.1	8.0	5.5	2.9	7.9	8.2	5.5	3.0	7.8	8.3	5.6	3.0	38.0
40.0	7.4	7.8	5.4	2.8	7.3	7.7	5.4	2.9	7.1	7.6	5.5	2.9	40.0
42.0	6.9	7.3	5.3	2.8	6.7	7.1	5.4	2.8	6.6	7.0	5.4	2.8	42.0
44.0	6.3	6.7	5.2	2.7	6.2	6.6	5.3	2.7	6.1	6.5	5.3	2.8	44.0
46.0		6.2	5.2	2.7	5.7	6.1	5.2	2.7	5.6	6.0	5.3	2.7	46.0
48.0		5.8	5.1	2.6	5.3	5.7	5.2	2.6	5.1	5.5	5.2	2.7	48.0
50.0		5.4	5.0	2.6		5.3	5.1	2.6	4.8	5.1	5.1	2.6	50.0
52.0		5.0	4.9	2.5		4.9	5.0	2.5		4.7	5.0	2.6	52.0
54.0			4.8	2.5		4.5	4.8	2.5		4.4	4.6	2.5	54.0
56.0			4.6	2.5			4.5	2.5		4.1	4.3	2.5	56.0
58.0				2.4			4.1	2.5			4.0	2.5	58.0
60.0				2.4			3.9	2.4			3.7	2.4	60.0
62.0				2.4				2.4			3.5	2.4	62.0
64.0								2.4				2.4	64.0
66.0								2.4				2.4	66.0

※表中の太線で囲まれた部分は、ブーム等の強度によって定められた値です。

●クローラークレーン●

ブーム長さ(m) 作業半径(m)	45.7				48.8				51.8				ブーム長さ(m) 作業半径(m)
	12.2	18.3	24.4	30.5	12.2	18.3	24.4	30.5	12.2	18.3	24.4	30.5	
16.0	10.0/17.5m												16.0
18.0	10.0				10.0/18.1m				10.0/18.6m				18.0
20.0	10.0	9.0/21.4m			10.0				10.0				20.0
22.0	10.0	9.0			10.0	9.0			10.0	9.0/22.5m			22.0
24.0	10.0	9.0	6.0/25.4m		10.0	9.0	6.0/25.9m		10.0	9.0			24.0
26.0	10.0	9.0	6.0		10.0	9.0	6.0		10.0	9.0	6.0/26.4m		26.0
28.0	10.0	9.0	6.0	3.0/29.3m	10.0	9.0	6.0	3.0/29.8m	10.0	9.0	6.0		28.0
30.0	10.0	9.0	6.0	3.0	10.0	9.0	6.0	3.0	10.0	9.0	6.0	3.0/30.3m	30.0
32.0	10.0	9.0	6.0	3.0	10.0	9.0	6.0	3.0	9.8	9.0	6.0	3.0	32.0
34.0	9.1	9.0	5.9	3.0	9.0	9.0	5.9	3.0	8.9	9.0	6.0	3.0	34.0
36.0	8.3	8.8	5.8	3.0	8.2	8.7	5.8	3.0	8.1	8.6	5.9	3.0	36.0
38.0	7.6	8.1	5.7	3.0	7.5	8.0	5.7	3.0	7.3	7.9	5.8	3.0	38.0
40.0	7.0	7.4	5.6	2.9	6.8	7.3	5.6	3.0	6.7	7.2	5.7	3.0	40.0
42.0	6.4	6.8	5.5	2.9	6.2	6.7	5.5	2.9	6.1	6.6	5.6	2.9	42.0
44.0	5.8	6.3	5.4	2.8	5.7	6.2	5.4	2.8	5.6	6.0	5.5	2.9	44.0
46.0	5.4	5.8	5.3	2.8	5.2	5.7	5.4	2.8	5.1	5.5	5.4	2.8	46.0
48.0	4.9	5.3	5.2	2.7	4.8	5.2	5.3	2.7	4.7	5.1	5.3	2.8	48.0
50.0	4.6	4.9	5.2	2.7	4.4	4.8	5.1	2.7	4.3	4.7	5.0	2.7	50.0
52.0	4.2	4.6	4.8	2.6	4.1	4.4	4.7	2.6	3.9	4.3	4.6	2.7	52.0
54.0		4.2	4.5	2.6	3.7	4.1	4.4	2.6	3.5	4.0	4.2	2.6	54.0
56.0		3.9	4.1	2.5	3.4	3.8	4.0	2.6	3.1	3.6	3.9	2.6	56.0
58.0		3.6	3.8	2.5		3.5	3.7	2.5	2.8	3.3	3.6	2.5	58.0
60.0		3.3	3.6	2.5		3.1	3.4	2.5		2.9	3.3	2.5	60.0
62.0			3.3	2.4		2.8	3.2	2.5		2.6	3.0	2.5	62.0
64.0			3.0	2.4			2.8	2.4		2.3	2.7	2.5	64.0
66.0				2.4			2.6	2.4			2.4	2.4	66.0
68.0				2.4			2.3	2.4			2.1	2.4	68.0
70.0				2.4				2.3				2.1	70.0
72.0								2.1					72.0

※表中の太線で囲まれた部分は、ブーム等の強度によって定められた値です。

ブーム長さ(m) 作業半径(m)	54.9				57.9				61.0				ブーム長さ(m) 作業半径(m)
	12.2	18.3	24.4	30.5	12.2	18.3	24.4	30.5	12.2	18.3	24.4	30.5	
18.0	10.0/19.1m				10.0/19.6m								18.0
20.0	10.0				10.0				10.0/20.1m				20.0
22.0	10.0	9.0/23.0m			10.0	9.0/23.6m			10.0				22.0
24.0	10.0	9.0			10.0	9.0			10.0	9.0/24.1m			24.0
26.0	10.0	9.0	6.0/26.9m		10.0	9.0	6.0/27.5m		10.0	9.0			26.0
28.0	10.0	9.0	6.0		10.0	9.0	6.0		10.0	9.0	6.0		28.0
30.0	10.0	9.0	6.0	3.0/30.9m	10.0	9.0	6.0	3.0/31.4m	10.0	9.0	6.0	3.0/31.9m	30.0
32.0	9.6	9.0	6.0	3.0	9.5	9.0	6.0	3.0	9.3	9.0	6.0	3.0	32.0
34.0	8.7	9.0	6.0	3.0	8.5	9.0	6.0	3.0	8.4	9.0	6.0	3.0	34.0
36.0	7.9	8.5	5.9	3.0	7.7	8.3	5.9	3.0	7.6	8.2	6.0	3.0	36.0
38.0	7.1	7.7	5.8	3.0	7.0	7.6	5.8	3.0	6.8	7.4	5.9	3.0	38.0
40.0	6.5	7.0	5.7	3.0	6.3	6.9	5.7	3.0	6.2	6.8	5.8	3.0	40.0
42.0	5.9	6.4	5.6	3.0	5.7	6.3	5.7	3.0	5.6	6.1	5.7	3.0	42.0
44.0	5.4	5.9	5.5	2.9	5.2	5.7	5.6	2.9	5.1	5.6	5.6	3.0	44.0
46.0	4.9	5.4	5.5	2.8	4.7	5.2	5.5	2.9	4.6	5.1	5.5	2.9	46.0
48.0	4.5	4.9	5.2	2.8	4.3	4.8	5.1	2.8	4.1	4.6	5.0	2.8	48.0
50.0	4.1	4.5	4.8	2.7	3.8	4.4	4.7	2.8	3.6	4.2	4.6	2.8	50.0
52.0	3.6	4.1	4.4	2.7	3.4	4.0	4.3	2.7	3.2	3.8	4.2	2.7	52.0
54.0	3.2	3.8	4.1	2.6	3.0	3.6	3.9	2.7	2.8	3.4	3.8	2.7	54.0
56.0	2.8	3.4	3.7	2.6	2.6	3.2	3.6	2.6	2.4	3.0	3.4	2.7	56.0
58.0	2.5	3.0	3.4	2.6	2.3	2.8	3.2	2.6	2.0	2.6	3.0	2.6	58.0
60.0	2.2	2.7	3.1	2.5	2.0	2.5	2.9	2.6		2.3	2.7	2.6	60.0
62.0		2.4	2.7	2.5		2.2	2.5	2.5		2.0	2.3	2.5	62.0
64.0		2.1	2.4	2.5			2.2	2.5			2.0	2.3	64.0
66.0			2.1	2.4				2.2				2.0	66.0
68.0				2.1									68.0

※表中の太線で囲まれた部分は、ブーム等の強度によって定められた値です。

▶主ブーム定格総荷重表 (45.1tカウンタウエイト)(オプション)

(単位:t)

ジブの長さ (m) 作業半径(m)	15.2	18.3	21.3	24.4	27.4	30.5	33.5	36.6	39.6	42.7	45.7	48.8	51.8	54.9	57.9	61.0	ジブの長さ (m) 作業半径(m)
4.5	120.0																4.5
5.0	120.0	108.0/5.1m	96.0/5.6m														5.0
6.0	100.0	99.8	94.9	84.0/6.1m	74.6/6.7m												6.0
7.0	78.8	78.7	78.6	78.6	73.7	66.4/7.2m	59.4/7.7m										7.0
8.0	63.2	63.1	63.0	63.0	62.8	62.8	58.9	53.6/8.2m	48.0/8.8m								8.0
9.0	52.7	52.5	52.4	52.4	52.2	52.2	52.1	52.0	48.0	43.5/9.3m	39.6/9.8m						9.0
10.0	45.0	44.9	44.8	44.7	44.5	44.5	44.4	44.3	44.2	42.8	39.5	36.0/10.4m	32.1/10.9m	29.4/11.4m			10.0
12.0	34.8	34.6	34.4	34.4	34.2	34.1	34.1	33.9	33.8	33.7	33.5	33.5	31.4	29.0	26.9	24.0/12.5m	12.0
14.0	28.2	28.0	27.8	27.7	27.5	27.5	27.4	27.2	27.1	27.0	26.8	26.8	26.7	26.5	25.9	23.5	14.0
16.0	25.9/14.9m	23.4	23.2	23.1	22.9	22.8	22.7	22.5	22.5	22.3	22.2	22.1	22.0	21.8	21.6	21.6	16.0
18.0		20.8/17.5m	19.8	19.7	19.5	19.4	19.3	19.1	19.0	18.9	18.7	18.7	18.5	18.3	18.2	18.1	18.0
20.0			17.2	17.1	16.9	16.8	16.7	16.5	16.4	16.3	16.1	16.0	15.9	15.7	15.5	15.5	20.0
22.0			17.2/20.1m	15.1	14.8	14.7	14.6	14.4	14.3	14.2	14.0	13.9	13.8	13.6	13.4	13.4	22.0
24.0				14.4/22.8m	13.2	13.1	12.9	12.7	12.6	12.5	12.3	12.2	12.1	11.9	11.7	11.6	24.0
26.0					12.2/25.4m	11.7	11.6	11.3	11.3	11.1	10.9	10.8	10.7	10.5	10.3	10.2	26.0
28.0						10.5	10.4	10.2	10.1	9.9	9.7	9.7	9.5	9.3	9.1	9.1	28.0
30.0							9.4	9.2	9.1	8.9	8.7	8.6	8.5	8.3	8.1	8.0	30.0
32.0							9.1/30.7m	8.4	8.2	8.1	7.9	7.8	7.6	7.4	7.3	7.2	32.0
34.0								7.9/33.3m	7.5	7.3	7.1	7.0	6.9	6.7	6.5	6.4	34.0
36.0									6.9	6.7	6.5	6.4	6.2	6.0	5.8	5.7	36.0
38.0										6.1	5.9	5.8	5.6	5.4	5.3	5.1	38.0
40.0										6.0/38.6m	5.4	5.3	5.1	4.9	4.7	4.6	40.0
42.0											5.1/41.2m	4.8	4.6	4.4	4.2	4.1	42.0
44.0												4.4/43.9m	4.2	4.0	3.8	3.7	44.0
46.0													3.8	3.6	3.4	3.3	46.0
48.0													3.8/46.5m	3.3	3.1	2.9	48.0
50.0														3.1/49.2m	2.6	2.5	50.0
52.0															2.3/51.8m	2.1	52.0

※表中の太線で囲まれた部分は、ブーム等の強度によって定められた値です。

▶補助シーブ定格総荷重表 (45.1tカウンタウエイト、120tフック装着)(オプション)

(単位:t)

ジブの長さ (m) 作業半径(m)	15.2	18.3	21.3	24.4	27.4	30.5	33.5	36.6	39.6	42.7	45.7	48.8	51.8	54.9	57.9	61.0	ジブの長さ (m) 作業半径(m)
5.0	12.0/5.3m	12.0/5.8m															5.0
6.0	12.0	12.0	12.0/6.3m	12.0/6.9m													6.0
7.0	12.0	12.0	12.0	12.0	12.0/7.4m	12.0/7.9m											7.0
8.0	12.0	12.0	12.0	12.0	12.0	12.0	12.0/8.4m										8.0
9.0	12.0	12.0	12.0	12.0	12.0	12.0	12.0	12.0	12.0/9.5m								9.0
10.0	12.0	12.0	12.0	12.0	12.0	12.0	12.0	12.0	12.0	12.0	12.0/10.6m	12.0/11.1m	12.0/11.6m				10.0
12.0	12.0	12.0	12.0	12.0	12.0	12.0	12.0	12.0	12.0	12.0	12.0	12.0	12.0	12.0/12.2m	12.0/12.7m	12.0/13.2m	12.0
14.0	12.0	12.0	12.0	12.0	12.0	12.0	12.0	12.0	12.0	12.0	12.0	12.0	12.0	12.0	12.0	12.0	14.0
16.0	12.0	12.0	12.0	12.0	12.0	12.0	12.0	12.0	12.0	12.0	12.0	12.0	12.0	12.0	12.0	12.0	16.0
18.0	12.0/16.2m	12.0	12.0	12.0	12.0	12.0	12.0	12.0	12.0	12.0	12.0	12.0	12.0	12.0	12.0	12.0	18.0
20.0		12.0/18.8m	12.0	12.0	12.0	12.0	12.0	12.0	12.0	12.0	12.0	12.0	12.0	12.0	12.0	12.0	20.0
22.0			12.0/21.5m	12.0	12.0	12.0	12.0	12.0	12.0	12.0	12.0	11.9	11.8	11.6	11.4	11.4	22.0
24.0				11.3	11.2	11.1	10.9	10.7	10.6	10.5	10.3	10.2	10.1	9.9	9.7	9.6	24.0
26.0				11.2/24.1m	9.7	9.7	9.6	9.3	9.3	9.1	8.9	8.8	8.7	8.5	8.3	8.2	26.0
28.0					9.2/26.7m	8.5	8.4	8.2	8.1	7.9	7.7	7.7	7.5	7.3	7.1	7.1	28.0
30.0						7.6/29.4m	7.4	7.2	7.1	6.9	6.7	6.6	6.5	6.3	6.1	6.0	30.0
32.0							6.5	6.4	6.2	6.1	5.9	5.8	5.6	5.4	5.3	5.2	32.0
34.0								5.6	5.5	5.3	5.1	5.0	4.9	4.7	4.5	4.4	34.0
36.0								5.3/34.7m	4.9	4.7	4.5	4.4	4.2	4.0	3.8	3.7	36.0
38.0									4.5/37.3m	4.1	3.9	3.8	3.6	3.4	3.3	3.1	38.0
40.0										3.7/39.9m	3.4	3.3	3.1	2.9	2.7	2.6	40.0
42.0											2.9	2.8	2.6	2.4	2.2	2.1	42.0
44.0											2.7/42.6m	2.3	2.2	2.0			44.0
46.0												2.1/45.2m					46.0

※表中の太線で囲まれた部分は、ブーム等の強度によって定められた値です。

▶ 補助シーブ定格総荷重表 (45.1tカウンタウエイト、70tフック装着)(オプション)

(単位:t)

ジブの長さ 作業半径(m)	15.2	18.3	21.3	24.4	27.4	30.5	33.5	36.6	39.6	42.7	45.7	48.8	51.8	54.9	57.9	61.0	ジブの長さ 作業半径(m)
5.0	12.0/5.3m	12.0/5.8m															5.0
6.0	12.0	12.0	12.0/6.3m	12.0/6.9m													6.0
7.0	12.0	12.0	12.0	12.0	12.0/7.4m	12.0/7.9m											7.0
8.0	12.0	12.0	12.0	12.0	12.0	12.0	12.0/8.4m										8.0
9.0	12.0	12.0	12.0	12.0	12.0	12.0	12.0	12.0	12.0/9.5m								9.0
10.0	12.0	12.0	12.0	12.0	12.0	12.0	12.0	12.0	12.0	12.0	12.0/10.6m	12.0/11.1m	12.0/11.6m				10.0
12.0	12.0	12.0	12.0	12.0	12.0	12.0	12.0	12.0	12.0	12.0	12.0	12.0	12.0	12.0/12.2m	12.0/12.7m	12.0/13.2m	12.0
14.0	12.0	12.0	12.0	12.0	12.0	12.0	12.0	12.0	12.0	12.0	12.0	12.0	12.0	12.0	12.0	12.0	14.0
16.0	12.0	12.0	12.0	12.0	12.0	12.0	12.0	12.0	12.0	12.0	12.0	12.0	12.0	12.0	12.0	12.0	16.0
18.0	12.0/16.2m	12.0	12.0	12.0	12.0	12.0	12.0	12.0	12.0	12.0	12.0	12.0	12.0	12.0	12.0	12.0	18.0
20.0		12.0/18.8m	12.0	12.0	12.0	12.0	12.0	12.0	12.0	12.0	12.0	12.0	12.0	12.0	12.0	12.0	20.0
22.0			12.0/21.5m	12.0	12.0	12.0	12.0	12.0	12.0	12.0	12.0	12.0	12.0	12.0	11.9	11.9	22.0
24.0				11.8	11.7	11.6	11.4	11.2	11.1	11.0	10.8	10.7	10.6	10.4	10.2	10.1	24.0
26.0				11.7/24.1m	10.2	10.2	10.1	9.8	9.8	9.6	9.4	9.3	9.2	9.0	8.8	8.7	26.0
28.0					9.7/26.7m	9.0	8.9	8.7	8.6	8.4	8.2	8.2	8.0	7.8	7.6	7.6	28.0
30.0						8.1/29.4m	7.9	7.7	7.6	7.4	7.2	7.1	7.0	6.8	6.6	6.5	30.0
32.0							7.0	6.9	6.7	6.6	6.4	6.3	6.1	5.9	5.8	5.7	32.0
34.0								6.1	6.0	5.8	5.6	5.5	5.4	5.2	5.0	4.9	34.0
36.0								5.8/34.7m	5.4	5.2	5.0	4.9	4.7	4.5	4.3	4.2	36.0
38.0									5.0/37.3m	4.6	4.4	4.3	4.1	3.9	3.8	3.6	38.0
40.0										4.2/39.9m	3.9	3.8	3.6	3.4	3.2	3.1	40.0
42.0											3.4	3.3	3.1	2.9	2.7	2.6	42.0
44.0											3.2/42.6m	2.8	2.7	2.5	2.3	2.2	44.0
46.0												2.6/45.2m	2.3	2.1			46.0
48.0													2.0/47.9m				48.0

※表中の太線で囲まれた部分は、ブーム等の強度によって定められた値です。

▶ 補助シーブ定格総荷重表 (45.1tカウンタウエイト、35tフック装着)(オプション)

(単位:t)

ジブの長さ 作業半径(m)	15.2	18.3	21.3	24.4	27.4	30.5	33.5	36.6	39.6	42.7	45.7	48.8	51.8	54.9	57.9	61.0	ジブの長さ 作業半径(m)
5.0	12.0/5.3m	12.0/5.8m															5.0
6.0	12.0	12.0	12.0/6.3m	12.0/6.9m													6.0
7.0	12.0	12.0	12.0	12.0	12.0/7.4m	12.0/7.9m											7.0
8.0	12.0	12.0	12.0	12.0	12.0	12.0	12.0/8.4m										8.0
9.0	12.0	12.0	12.0	12.0	12.0	12.0	12.0	12.0	12.0/9.5m								9.0
10.0	12.0	12.0	12.0	12.0	12.0	12.0	12.0	12.0	12.0	12.0	12.0/10.6m	12.0/11.1m	12.0/11.6m				10.0
12.0	12.0	12.0	12.0	12.0	12.0	12.0	12.0	12.0	12.0	12.0	12.0	12.0	12.0	12.0/12.2m	12.0/12.7m	12.0/13.2m	12.0
14.0	12.0	12.0	12.0	12.0	12.0	12.0	12.0	12.0	12.0	12.0	12.0	12.0	12.0	12.0	12.0	12.0	14.0
16.0	12.0	12.0	12.0	12.0	12.0	12.0	12.0	12.0	12.0	12.0	12.0	12.0	12.0	12.0	12.0	12.0	16.0
18.0	12.0/16.2m	12.0	12.0	12.0	12.0	12.0	12.0	12.0	12.0	12.0	12.0	12.0	12.0	12.0	12.0	12.0	18.0
20.0		12.0/18.8m	12.0	12.0	12.0	12.0	12.0	12.0	12.0	12.0	12.0	12.0	12.0	12.0	12.0	12.0	20.0
22.0			12.0/21.5m	12.0	12.0	12.0	12.0	12.0	12.0	12.0	12.0	12.0	12.0	12.0	12.0	12.0	22.0
24.0				12.0	12.0	11.9	11.7	11.5	11.4	11.3	11.1	11.0	10.9	10.7	10.5	10.4	24.0
26.0				12.0/24.1m	10.5	10.5	10.4	10.1	10.1	9.9	9.7	9.6	9.5	9.3	9.1	9.0	26.0
28.0					10.0/26.7m	9.3	9.2	9.0	8.9	8.7	8.5	8.5	8.3	8.1	7.9	7.9	28.0
30.0						8.4/29.4m	8.2	8.0	7.9	7.7	7.5	7.4	7.3	7.1	6.9	6.8	30.0
32.0							7.3	7.2	7.0	6.9	6.7	6.6	6.4	6.2	6.1	6.0	32.0
34.0								6.4	6.3	6.1	5.9	5.8	5.7	5.5	5.3	5.2	34.0
36.0								6.1/34.7m	5.7	5.5	5.3	5.2	5.0	4.8	4.6	4.5	36.0
38.0									5.3/37.3m	4.9	4.7	4.6	4.4	4.2	4.1	3.9	38.0
40.0										4.5/39.9m	4.2	4.1	3.9	3.7	3.5	3.4	40.0
42.0											3.7	3.6	3.4	3.2	3.0	2.9	42.0
44.0											3.5/42.6m	3.1	3.0	2.8	2.6	2.5	44.0
46.0												2.9/45.2m	2.6	2.4	2.2	2.1	46.0
48.0													2.3/47.9m	2.1			48.0

※表中の太線で囲まれた部分は、ブーム等の強度によって定められた値です。

▶ 補助シーブ定格総荷重表 (45.1カウンタウエイト、主フックなし)(オプション)

(単位:t)

ジブの長さ 作業半径(m)	15.2	18.3	21.3	24.4	27.4	30.5	33.5	36.6	39.6	42.7	45.7	48.8	51.8	54.9	57.9	61.0	ジブの長さ 作業半径(m)
5.0	12.0/5.3m	12.0/5.8m															5.0
6.0	12.0	12.0	12.0/6.3m	12.0/6.9m													6.0
7.0	12.0	12.0	12.0	12.0	12.0/7.4m	12.0/7.9m											7.0
8.0	12.0	12.0	12.0	12.0	12.0	12.0	12.0/8.4m										8.0
9.0	12.0	12.0	12.0	12.0	12.0	12.0	12.0	12.0	12.0/9.5m								9.0
10.0	12.0	12.0	12.0	12.0	12.0	12.0	12.0	12.0	12.0	12.0	12.0/10.6m	12.0/11.1m	12.0/11.6m				10.0
12.0	12.0	12.0	12.0	12.0	12.0	12.0	12.0	12.0	12.0	12.0	12.0	12.0	12.0	12.0/12.2m	12.0/12.7m	12.0/13.2m	12.0
14.0	12.0	12.0	12.0	12.0	12.0	12.0	12.0	12.0	12.0	12.0	12.0	12.0	12.0	12.0	12.0	12.0	14.0
16.0	12.0	12.0	12.0	12.0	12.0	12.0	12.0	12.0	12.0	12.0	12.0	12.0	12.0	12.0	12.0	12.0	16.0
18.0	12.0/16.2m	12.0	12.0	12.0	12.0	12.0	12.0	12.0	12.0	12.0	12.0	12.0	12.0	12.0	12.0	12.0	18.0
20.0		12.0/18.8m	12.0	12.0	12.0	12.0	12.0	12.0	12.0	12.0	12.0	12.0	12.0	12.0	12.0	12.0	20.0
22.0			12.0/21.5m	12.0	12.0	12.0	12.0	12.0	12.0	12.0	12.0	12.0	12.0	12.0	12.0	12.0	22.0
24.0				12.0	12.0	12.0	12.0	12.0	12.0	12.0	12.0	11.9	11.8	11.6	11.4	11.3	24.0
26.0				12.0/24.1m	11.4	11.4	11.3	11.0	11.0	10.8	10.6	10.5	10.4	10.2	10.0	9.9	26.0
28.0					10.9/26.7m	10.2	10.1	9.9	9.8	9.6	9.4	9.4	9.2	9.0	8.8	8.8	28.0
30.0						9.3/29.4m	9.1	8.9	8.8	8.6	8.4	8.3	8.2	8.0	7.8	7.7	30.0
32.0							8.2	8.1	7.9	7.8	7.6	7.5	7.3	7.1	7.0	6.9	32.0
34.0								7.3	7.2	7.0	6.8	6.7	6.6	6.4	6.2	6.1	34.0
36.0								7.0/34.7m	6.6	6.4	6.2	6.1	5.9	5.7	5.5	5.4	36.0
38.0									6.2/37.3m	5.8	5.6	5.5	5.3	5.1	5.0	4.8	38.0
40.0										5.4/39.9m	5.1	5.0	4.8	4.6	4.4	4.3	40.0
42.0											4.6	4.5	4.3	4.1	3.9	3.8	42.0
44.0											4.4/42.6m	4.0	3.9	3.7	3.5	3.4	44.0
46.0												3.8/45.2m	3.5	3.3	3.1	3.0	46.0
48.0													3.2/47.9m	3.0	2.8	2.6	48.0
50.0														2.6	2.3	2.2	50.0
52.0															2.5/50.5m		52.0

※表中の太線で囲まれた部分は、ブーム等の強度によって定められた値です。

ラッピングタワー

▶全体図(単位: mm)

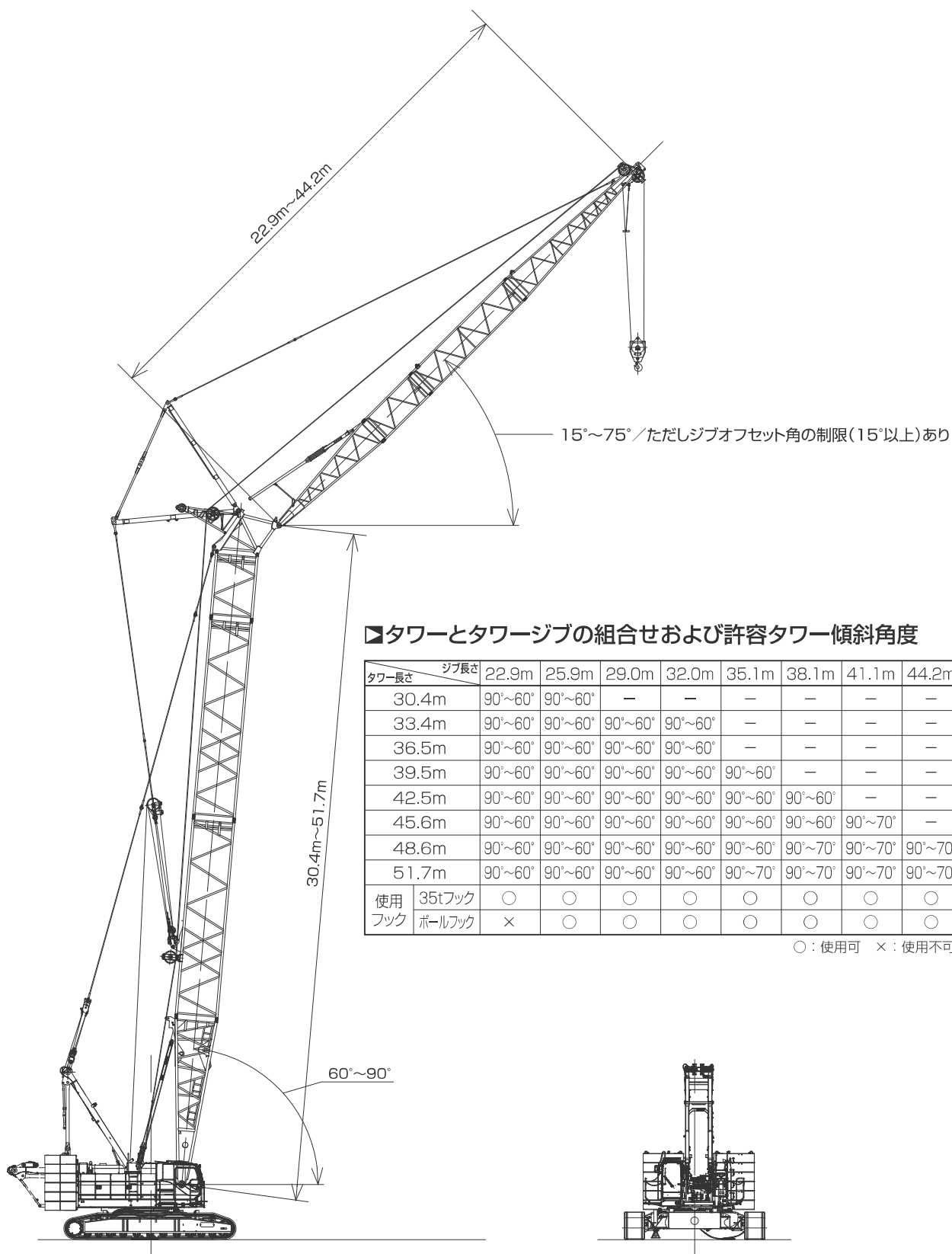

▼タワーとタワージブの組合せおよび許容タワー傾斜角度

タワー長さ	ジブ長さ	22.9m	25.9m	29.0m	32.0m	35.1m	38.1m	41.1m	44.2m	敷板
30.4m		90°~60°	90°~60°	—	—	—	—	—	—	—
33.4m		90°~60°	90°~60°	90°~60°	90°~60°	—	—	—	—	—
36.5m		90°~60°	90°~60°	90°~60°	90°~60°	—	—	—	—	—
39.5m		90°~60°	90°~60°	90°~60°	90°~60°	90°~60°	—	—	—	—
42.5m		90°~60°	90°~60°	90°~60°	90°~60°	90°~60°	90°~60°	—	—	—
45.6m		90°~60°	90°~60°	90°~60°	90°~60°	90°~60°	90°~60°	90°~70°	—	—
48.6m		90°~60°	90°~60°	90°~60°	90°~60°	90°~60°	90°~70°	90°~70°	90°~70°	—
51.7m		90°~60°	90°~60°	90°~60°	90°~60°	90°~70°	90°~70°	90°~70°	90°~70°	◎
使用	35tフック	○	○	○	○	○	○	○	○	⊗
フック	ボールフック	×	○	○	○	○	○	○	○	

○: 使用可 ×: 使用不可 ◎: 必要

▶タワー構成

- ※印は、これより短いタワーの組立可能な構成を示します。
- 9.1Aは、クローラークレーンの中間ブームとしても使用できます。
- 下部ブーム直近の9.1m中間ブームには、9.1Aを使用してください。
- 使用するガイラインの径はφ30mmです。

中間タワーの種類		
記号	タワー長さ	備考
3.0	3.0m	クレーンおよびタワー共用
6.1	6.1m	クレーンおよびタワー共用
9.1	9.1m	クレーンおよびタワー共用
9.1A	9.1m	タワー専用 (クレーンに兼用可能)

▶タワージブ構成

- ※印は、これより短いタワージブの組立可能な構成を示します。
- 印は、ケーブルローラ取付位置を示します。
- 使用するガイラインの径はφ30mmです。

中間タワージブの種類		
記号	タワージブ長さ	備考
3.0A	3.0m	中継ジブ
3.0	3.0m	
6.1	6.1m	
9.1	9.1m	

タワー長さ m (ft.)	タワー構成
30.4 (100)	
33.4 (110)	
36.5 (120)	
39.5 (130)	
42.5 (140)	
45.6 (150)	
48.6 (160)	
51.7 (170)	

タワー長さ m (ft.)	タワージブ構成
22.9 (75)	
25.9 (85)	
29.0 (95)	
32.0 (105)	
35.1 (115)	
38.1 (125)	
41.1 (135)	
44.2 (145)	

▶定格総荷重

- 定格総荷重とは、水平堅土上における転倒荷重の78%以内で、フックブロック、玉掛用ワイヤロープ等のつり具の質量を含んだ値です。
- 作業半径とはクレーン旋回中心よりつり上荷重の重心までの水平距離を意味します。
- 実際につり上げ得る荷重は定格総荷重から（主フック+玉掛用ワイヤロープ等のつり具）の質量を差し引いた値になります。
- 定格総荷重をつる場合にも風の影響、地盤の状態、作業速度その他安全作業に有害な状況がある時はオペレータは荷重の軽減、作業速度を遅くするなど状況に応じた判断をする責任があります。
- 表中の空欄の個所では作業を行うことができません。
- クレーン作業中はガントリを最高位置に立ててください。

- すべてのタワー（ジブ）長さにおける中間タワーブーム（ジブ）の構成は取扱説明書の指示を厳守してください。
- ジブ長さ22.9mにてボールフックの使用はできません。
- 51.7mタワーの自立、降下の際にはクローラの前端に敷板（ブロック）を敷いてください。

△ 操作ミスなどによるつり荷の落下を防ぐため、クレーン作業では自由降下（フリーフォール）作業は行わないでください。

- 巻上げロープ巻掛本数に対する最大巻上荷重とフックの質量

フック呼称	35t	ボールフック
最大巻上荷重 (t)	1本掛 12.0 2本掛 20.0	12.0 -
フック質量	0.90t	0.45t

▶タワー長さ 30.4m

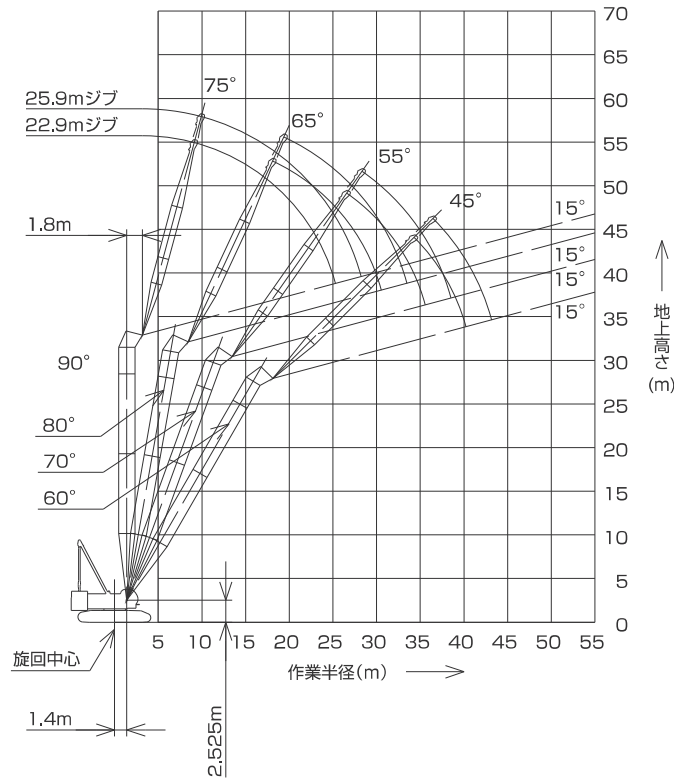

(単位:t)

タワー長さm	30.4								タワー長さm
ジブ長さm	22.9				25.9				ジブ長さm
タワー角度	90°	80°	70°	60°	90°	80°	70°	60°	タワー角度
作業半径(m)	9.4	20.0							9.4
	10.0	20.0			20.0/10.2m				10.0
	12.0	20.0			20.0				12.0
	14.0	20.0			20.0				14.0
	15.0	20.0			20.0				15.0
	16.0	18.7			18.7				16.0
	18.0	16.6	16.3/18.4m		16.6	15.2/19.7m			18.0
	20.0	15.0	15.0		15.0	15.0			20.0
	22.0	13.3	13.6		13.6	13.6			22.0
	24.0	9.9	12.5		12.1	12.5			24.0
	26.0	7.1/25.4m	11.5	11.1/26.8m	9.5	11.5			26.0
	28.0		10.7	10.7	6.7	10.7	10.4/28.6m		28.0
	30.0		10.0	10.0	6.1/28.3m	10.0	10.0		30.0
	32.0		9.4/30.6m	9.3		9.3	9.3		32.0
	34.0			8.8	8.5/34.5m	7.7/33.5m	8.8		34.0
	36.0			8.4/35.6m	7.9		8.3	7.7/36.7m	36.0
38.0				7.5		7.8	7.3	38.0	
40.0				7.0		7.7/38.6m	6.9	40.0	
42.0				6.9/40.3m			6.4	42.0	
44.0							6.2/43.2m	44.0	

*表中の太線で囲まれた部分は、ブーム等の強度によって定められた値です。

▶タワー長さ **33.4m**

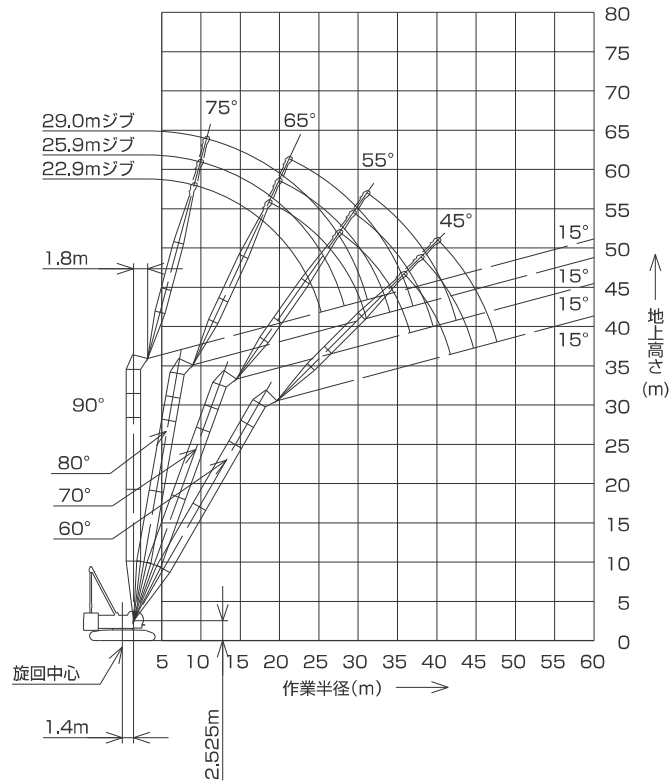

(単位:t)

タワー長さm	33.4												タワー長さm
ジブ長さm	22.9				25.9				29.0				ジブ長さm
タワー角度	90°	80°	70°	60°	90°	80°	70°	60°	90°	80°	70°	60°	タワー角度
9.4	20.0												9.4
10.0	20.0				20.0/10.2m				20.0/11.0m				10.0
12.0	20.0				20.0				20.0				12.0
14.0	20.0				20.0				20.0				14.0
15.0	20.0				20.0				20.0				15.0
16.0	18.7				18.7				18.7				16.0
18.0	16.6	15.8/18.9m			16.6				16.6				18.0
20.0	15.0	15.0			15.0	14.8/20.2m			15.0	13.9/21.5m			20.0
22.0	13.4	13.6			13.6	13.6			13.6	13.6			22.0
24.0	10.0	12.5			12.3	12.5			12.5	12.5			24.0
26.0	7.2/25.4m	11.5	10.7/27.9m		9.7	11.5			11.2	11.5			26.0
28.0		10.7	10.7		6.9	10.7	10.1/29.6m		9.1	10.7			28.0
30.0		10.0	10.0		6.2/28.3m	10.0	10.0		7.0	10.0	9.5/31.4m		30.0
32.0		9.5/31.1m	9.3			9.3	9.3		5.3/31.2m	9.3	9.3		32.0
34.0			8.8			8.6	8.8			8.8	8.8		34.0
36.0			8.3	7.6		8.1/34.1m	8.3			8.3	8.3		36.0
38.0			8.1/36.7m	7.0			7.8	6.9/38.2m		7.0/37.0m	7.8		38.0
40.0				6.6			7.5/39.6m	6.4			7.4	6.3/40.3m	40.0
42.0				6.2/41.8m				6.1			6.9	5.8	42.0
44.0								5.7			6.8/42.6m	5.6	44.0
46.0								5.6/44.8m				5.2	46.0
48.0												5.0/47.7m	48.0

※表中の太線で囲まれた部分は、ブーム等の強度によって定められた値です。

▶タワー長さ 36.5m

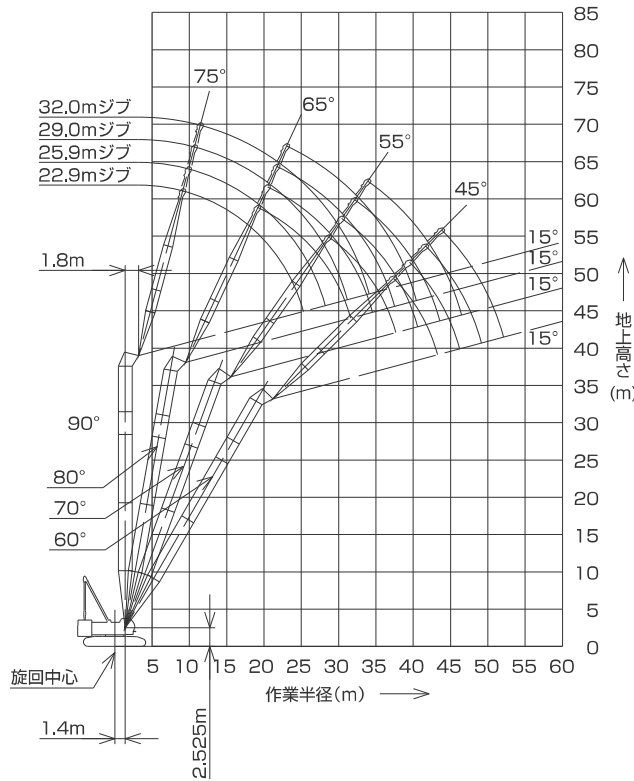

(単位:t)

タワー長さm	36.5																タワー長さm
ジブ長さm	22.9				25.9				29.0				32.0				ジブ長さm
タワー角度	90°	80°	70°	60°	90°	80°	70°	60°	90°	80°	70°	60°	90°	80°	70°	60°	タワー角度
作業半径(m)	9.4	20.0															9.4
	10.0	20.0			20.0/10.2m				20.0/11.0m				20.0/11.8m				10.0
	12.0	20.0			20.0				20.0				20.0				12.0
	14.0	20.0			20.0				20.0				19.6				14.0
	15.0	20.0			20.0				20.0				19.1				15.0
	16.0	18.7			18.7				18.7				18.6				16.0
	18.0	16.6	15.4/19.4m		16.6				16.6				16.6				18.0
	20.0	15.0	15.0		15.0	14.4/20.7m			15.0				15.0				20.0
	22.0	13.5	13.6		13.6	13.6			13.6	13.6			13.6	12.8/23.3m			22.0
	24.0	10.1	12.5		12.4	12.5			12.5	12.5			12.5	12.5			24.0
	26.0	7.3/25.4m	11.5		9.8	11.5			11.2	11.5			11.5	11.5			26.0
	28.0		10.7	10.3/28.9m	6.9	10.7			9.2	10.7			10.2	10.7			28.0
	30.0		10.0	10.0	6.3/28.3m	10.0	9.7/30.7m		7.1	10.0			8.6	10.0			30.0
	32.0		9.4/31.7m	9.3		9.3	9.3		5.4/31.2m	9.3	9.2/32.4m		6.9	9.3			32.0
	34.0			8.8		8.8	8.8			8.8	8.7		5.0	8.8	8.6/34.2m		34.0
	36.0			8.3	6.8/37.6m	8.2/34.6m	8.3			8.3	8.2		4.6/34.2m	8.3	8.0		36.0
	38.0			7.9/37.7m	6.6		7.8	6.2/39.7m		7.1/37.6m	7.7			7.8	7.6		38.0
	40.0				6.2		7.2	6.0			7.2	5.6/41.9m		7.0	7.1		40.0
	42.0				5.8		7.1/40.7m	5.7			6.7	5.5		6.2/40.5m	6.6		42.0
	44.0				5.6/43.3m			5.4			6.3/43.6m	5.2			6.2	5.0	44.0
46.0							5.0				4.9			5.9	4.7	46.0	
48.0							5.0/46.3m				4.6			5.7/46.5m	4.6	48.0	
50.0											4.4/49.2m				4.3	50.0	
52.0															4.0	52.0	
54.0															3.8/52.2m	54.0	

※表中の太線で囲まれた部分は、ブーム等の強度によって定められた値です。

▶タワー長さ 39.5m

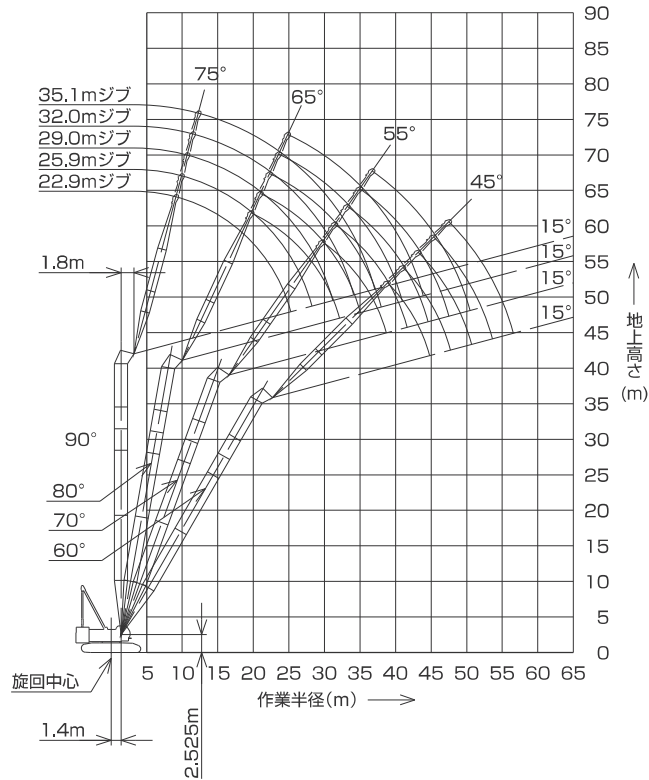

(単位:t)

タワー長さm	39.5																タワー長さm				
ジブ長さm	22.9				25.9				29.0				32.0				35.1				ジブ長さm
タワー角度	90°	80°	70°	60°	90°	80°	70°	60°	90°	80°	70°	60°	90°	80°	70°	60°	90°	80°	70°	60°	タワー角度
9.4	20.0																				9.4
10.0	20.0				20.0/10.2m				20.0/11.0m				20.0/11.8m								10.0
12.0	20.0				20.0				20.0				20.0				16.5/12.5m				12.0
14.0	20.0				20.0				20.0				19.6				16.3				14.0
15.0	20.0				20.0				20.0				19.1				16.0				15.0
16.0	18.7				18.7				18.7				18.6				15.7				16.0
18.0	16.6				16.6				16.6				16.6				15.3				18.0
20.0	15.0	15.0			15.0	14.1/21.2m			15.0				15.0				14.9				20.0
22.0	13.6	13.6			13.6	13.6			13.6	13.3/22.5m			13.6	12.6/23.9m			13.6				22.0
24.0	10.2	12.5			12.4	12.5			12.5	12.5			12.5	12.5			12.5	11.9/25.1m			24.0
26.0	7.4/25.4m	11.5			9.8	11.5			11.3	11.5			11.5	11.5			11.5	11.5			26.0
28.0		10.7			7.0	10.7			9.3	10.7			10.2	10.7			10.7	10.7			28.0
30.0		10.0	10.0		6.3/26.3m	10.0	9.4/31.7m		7.2	10.0			8.6	10.0			9.4	10.0			30.0
32.0		9.3	9.3			9.3	9.2		5.4/31.2m	9.3	8.6/33.5m		6.9	9.3			8.0	9.3			32.0
34.0		9.3/32.2m	8.7			8.8	8.6			8.8	8.4		5.0	8.8	8.0/35.2m		6.7	8.8			34.0
36.0			8.1			8.2/35.1m	8.0			8.3	7.9		4.7/34.2m	8.3	7.7		5.2	8.3	7.4/36.9m		36.0
38.0			7.5	6.0/39.1m			7.5			7.5	7.3			7.8	7.2		4.1/37.1m	7.8	7.0		38.0
40.0			7.3/38.8m	5.7			7.0	5.3/41.2m		7.1/36.1m	6.9			7.4	6.8			7.5	6.7		40.0
42.0				5.4			6.5/41.7m	5.2			6.4	4.7/43.4m		6.3	6.3			7.1	6.3		42.0
44.0				5.1				5.0			6.0	4.7			6.0	4.3/45.5m		5.4	5.9		44.0
46.0				4.9/44.9m				4.7			5.9/44.6m	4.5			5.6	4.3			5.5	4.0/47.7m	46.0
48.0								4.4/47.8m				4.3			5.3/47.6m	4.2			5.2	4.0	48.0
50.0												4.0				3.9			4.9	3.8	50.0
52.0												3.9/50.8m				3.7			4.8/50.5m	3.6	52.0
54.0																3.5/53.7m				3.4	54.0
56.0																				3.2	56.0
58.0																				3.1/56.6m	58.0

*表中の太線で囲まれた部分は、ブーム等の強度によって定められた値です。

▶タワー長さ 42.5m

(単位:t)

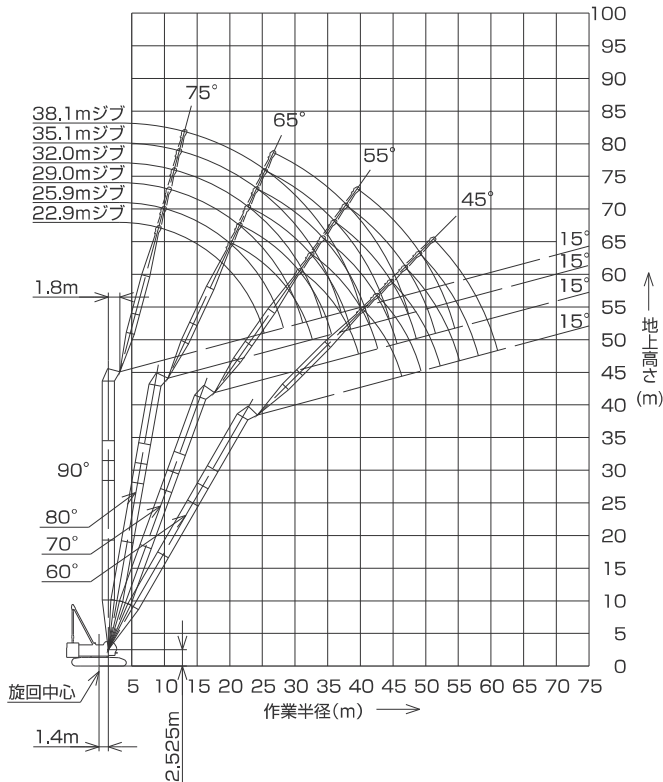

タワー長さm	42.5				タワー長さm
ジブ長さm	22.9				ジブ長さm
タワー角度	90°	80°	70°	60°	タワー角度
9.4	20.0				9.4
10.0	20.0				10.0
12.0	20.0				12.0
14.0	20.0				14.0
15.0	20.0				15.0
16.0	18.7				16.0
18.0	16.6				18.0
20.0	15.0	14.6/20.5m			20.0
22.0	13.6	13.6			22.0
24.0	10.3	12.5			24.0
26.0	7.5/25.4m	11.5			26.0
28.0		10.7			28.0
30.0		10.0	9.5/31.0m		30.0
32.0		9.3	9.0		32.0
34.0		9.1/32.7m	8.4		34.0
36.0			7.8		36.0
38.0			7.3		38.0
40.0			6.8/39.8m	5.2/40.6m	40.0
42.0				5.0	42.0
44.0				4.7	44.0
46.0				4.4	46.0
48.0				4.3/46.4m	48.0
50.0					50.0
52.0					52.0
54.0					54.0
56.0					56.0
58.0					58.0
60.0					60.0

(単位:t)

タワー長さm	42.5																タワー長さm				
ジブ長さm	25.9				29.0				32.0				35.1				38.1				ジブ長さm
タワー角度	90°	80°	70°	60°	90°	80°	70°	60°	90°	80°	70°	60°	90°	80°	70°	60°	90°	80°	70°	60°	タワー角度
9.4																					9.4
10.0	20.0/10.2m				20.0/11.0m				20.0/11.8m												10.0
12.0	20.0				20.0				20.0				16.5/12.5m				13.6/13.3m				12.0
14.0	20.0				20.0				19.5				16.2				13.6				14.0
15.0	20.0				20.0				19.0				16.0				13.4				15.0
16.0	18.7				18.7				18.5				15.7				13.1				16.0
18.0	16.6				16.6				16.6				15.3				12.7				18.0
20.0	15.0	13.7/21.8m			15.0				15.0				14.8				12.3				20.0
22.0	13.6	13.6			13.6	12.9/23.1m			13.6				13.6				11.9				22.0
24.0	12.5	12.5			12.5	12.5			12.5	12.2/24.4m			12.5	11.7/25.6m			11.6				24.0
26.0	9.9	11.5			11.3	11.5			11.5	11.5			11.5	11.5			11.2	11.1/26.9m			26.0
28.0	7.1	10.7			9.3	10.7			10.3	10.7			10.7	10.7			10.5	10.7			28.0
30.0	6.4/28.3m	10.0			7.2	10.0			8.7	10.0			9.4	10.0			9.6	10.0			30.0
32.0		9.3	8.7/32.7m		6.5/31.2m	9.3			7.0	9.3			8.0	9.3			8.5	9.3			32.0
34.0		8.8	8.2		8.8	8.0/34.5m			5.1	8.8			6.7	8.8			7.4	8.8			34.0
36.0		8.2/35.7m	7.7		8.3	7.5			4.7/34.2m	8.3	7.4/36.2m		5.3	8.3			6.3	8.3			36.0
38.0			7.2		7.8	7.1			7.8	6.8			4.1/37.1m	7.8	6.8		5.1	7.8	6.3/39.7m		38.0
40.0			6.7		7.1/38.6m	6.6			7.5	6.5				7.5	6.4		3.7	7.5	6.1		40.0
42.0			6.3	4.6/42.8m		6.2			6.2/41.5m	6.1			7.1	6.0		3.5/40.1m	7.1	5.9			42.0
44.0			6.1/42.7m	4.5		5.8	4.2/44.9m			5.7			6.1	5.6			6.7	5.5			44.0
46.0				4.3		5.4/45.7m	4.1			5.4	3.8/47.1m		5.4/44.5m	5.3			5.9	5.2			46.0
48.0				4.1			3.9			5.0	3.7			5.0	3.4/49.2m		4.7/47.4m	4.9			48.0
50.0				3.9/49.3m			3.7			4.9/48.6m	3.6			4.7	3.4			4.6	3.2/51.4m		50.0
52.0							3.5				3.4			4.4/51.6m	3.3			4.3	3.1		52.0
54.0							3.4/52.3m				3.2				3.1			4.1	3.0		54.0
56.0											3.0/55.2m				2.9			3.8/54.5m	2.8		56.0
58.0															2.8				2.6		58.0
60.0																2.7/58.2m			2.5		60.0
62.0																			2.4/61.1m		62.0

※表中の太線で囲まれた部分は、ブーム等の強度によって定められた値です。

▶タワー長さ 45.6m

(単位:t)

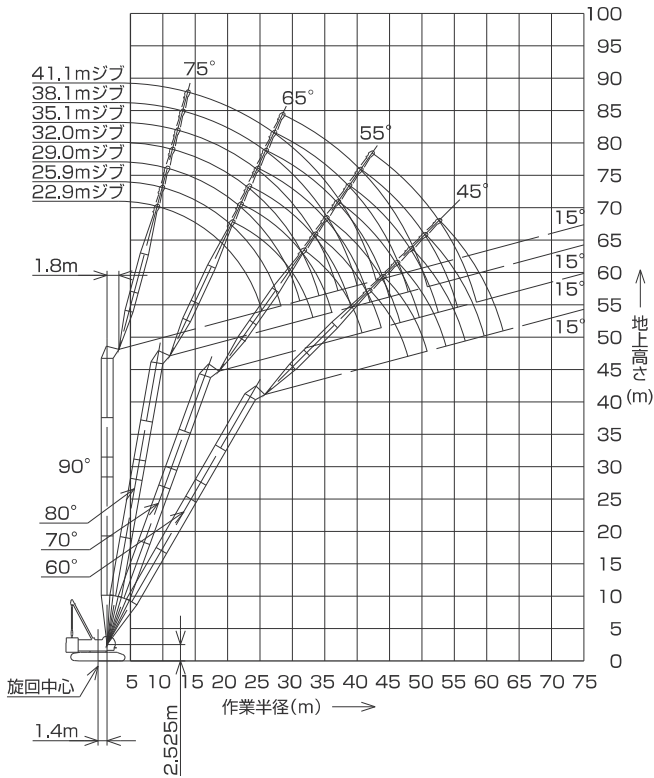

タワー長さm		45.6								タワー長さm
ジブ長さm		22.9				25.9				ジブ長さm
タワー角度		90°	80°	70°	60°	90°	80°	70°	60°	タワー角度
作業半径(m)	9.4	20.0								9.4
	10.0	20.0				20.0/10.2m				10.0
	12.0	20.0				20.0				12.0
	14.0	20.0				20.0				14.0
	15.0	20.0				20.0				15.0
	16.0	18.7				18.7				16.0
	18.0	16.6				16.6				18.0
	20.0	15.0	14.2/21.0m			15.0				20.0
	22.0	13.6	13.6			13.6	13.4/22.3m			22.0
	24.0	10.3	12.5			12.5	12.5			24.0
	26.0	7.5/25.4m	11.5			9.9	11.5			26.0
	28.0		10.7			7.1	10.7			28.0
	30.0		10.0			6.4/28.3m	10.0			30.0
	32.0		9.3	8.7			9.3	8.0/33.8m		32.0
	34.0		9.0/33.2m	8.0			8.8	7.8		34.0
	36.0			7.5			8.3	7.4		36.0
	38.0			7.0			8.2/36.2m	6.9		38.0
	40.0			6.5				6.4		40.0
	42.0			6.3/40.8m	4.4/42.1m			6.0		42.0
	44.0				4.3			5.6/43.8m	4.0/44.3m	44.0
	46.0				4.1				3.9	46.0
	48.0				3.9/47.9m				3.7	48.0
	50.0								3.5	50.0
	52.0								3.4/50.9m	52.0
	54.0									54.0
	56.0									56.0
58.0									58.0	
60.0									60.0	

(単位:t)

タワー長さm		45.6																タワー長さm				
ジブ長さm		29.0				32.0				35.1				38.1				41.1				ジブ長さm
タワー角度		90°	80°	70°	60°	90°	80°	70°	60°	90°	80°	70°	60°	90°	80°	70°	60°	90°	80°	70°	タワー角度	
作業半径(m)	9.4																					9.4
	10.0	20.0/11.0m				20.0/11.8m																10.0
	12.0	20.0				20.0				16.5/12.5m				13.6/13.3m								12.0
	14.0	20.0				19.5				16.2				13.6						10.7/14.1m		14.0
	15.0	20.0				19.0				16.0				13.3						10.7		15.0
	16.0	18.7				18.5				15.7				13.1						10.5		16.0
	18.0	16.6				16.6				15.2				12.7						10.2		18.0
	20.0	15.0				15.0				14.8				12.3						9.8		20.0
	22.0	13.6	12.7/23.6m			13.6				13.6				11.9						9.5		22.0
	24.0	12.5	12.5			12.5	12.0/24.9m			12.5				11.6						9.2		24.0
	26.0	11.3	11.5			11.5	11.5			11.5	11.4/26.2m			11.1	10.9/27.5m				8.9			26.0
	28.0	9.3	10.7			10.3	10.7			10.7	10.7			10.5	10.7				8.6	9.8/28.7m		28.0
	30.0	7.2	10.0			8.7	10.0			9.4	10.0			9.6	10.0				8.3	9.6		30.0
	32.0	5.5/31.2m	9.3			7.0	9.3			8.1	9.3			8.5	9.3				7.8	9.3		32.0
	34.0		8.8	7.4/35.5m		5.2	8.8			6.7	8.8			7.4	8.8				7.3	8.8		34.0
	36.0		8.3	7.1		4.8/34.2m	8.3	6.8/37.3m		5.3	8.3			6.3	8.3				6.8	8.3		36.0
	38.0		7.8	6.8			7.8	6.5		4.1/37.1m	7.8	6.3/39.0m		5.1	7.8				6.2	7.8		38.0
	40.0		7.1/39.1m	6.3			7.5	6.2			7.5	6.0		3.8	7.5	5.7/40.8m			5.2	7.5		40.0
	42.0			5.9			6.5	5.8			7.1	5.7		3.5/40.1m	7.1	5.4		4.1	7.1	5.4/42.5m		42.0
	44.0			5.5			6.2/42.1m	5.5			6.8	5.4			6.7	5.2		3.2/43.0m	6.6	5.0		44.0
	46.0			5.2	3.6/46.4m			5.1			5.4/45.0m	5.1			6.2	4.9			6.2	4.8		46.0
	48.0			5.0/46.7m	3.5			4.8	3.3/48.6m			4.8			4.7	4.6			5.8	4.5		48.0
	50.0				3.4			4.4/49.7m	3.2			4.5	3.0/50.7m			4.4			5.2	4.3		50.0
	52.0				3.2				3.1			4.2	2.9			4.1	2.7/52.9m		4.3/50.9m	4.0		52.0
	54.0				3.0/53.8m				2.9			3.9/52.8m	2.8			3.9	2.6			3.8		54.0
	56.0								2.7				2.7			3.4/55.6m	2.5			3.5		56.0
58.0								2.6/56.7m				2.5				2.4			3.3		58.0	
60.0												2.3/59.7m				2.2			3.1/58.5m		60.0	
62.0																2.1					62.0	
64.0																	2.0/62.6m				64.0	

※表中の太線で囲まれた部分は、ブーム等の強度によって定められた値です。

▶タワー長さ 48.6m

(単位:t)

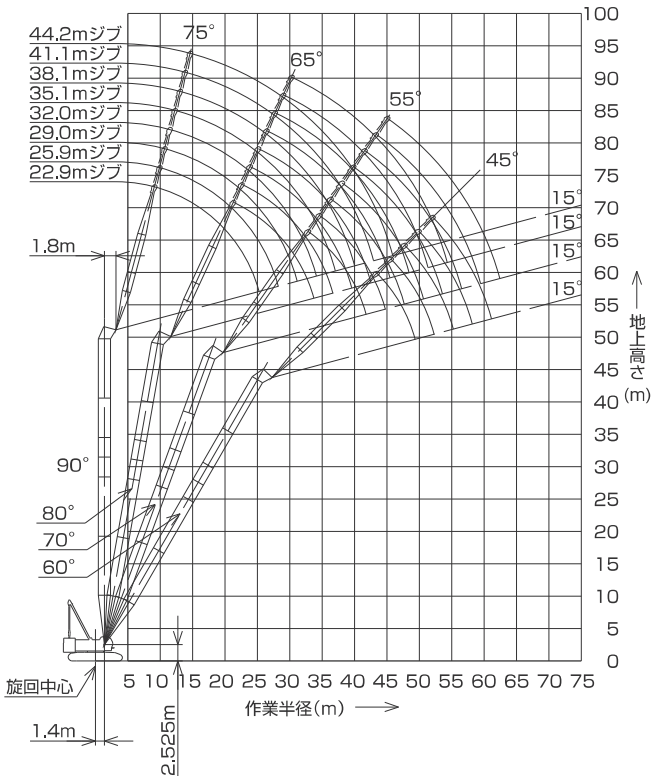

タワー長さm	48.6								タワー長さm
ジブ長さm	22.9				25.9				ジブ長さm
タワー角度	90°	80°	70°	60°	90°	80°	70°	60°	タワー角度
9.4	20.0								9.4
10.0	20.0				20.0/10.2m				10.0
12.0	20.0				20.0				12.0
14.0	20.0				20.0				14.0
15.0	20.0				19.8				15.0
16.0	18.7				18.7				16.0
18.0	16.6				16.6				18.0
20.0	15.0	13.9/21.5m			15.0				20.0
22.0	13.6	13.6			13.6	13.1/22.8m			22.0
24.0	10.4	12.5			12.5	12.5			24.0
26.0	7.5/25.4m	11.5			10.0	11.5			26.0
28.0		10.7			7.1	10.7			28.0
30.0		10.0			6.4/28.3m	10.0			30.0
32.0		9.3	8.0/33.1m			9.3			32.0
34.0		8.8/33.8m	7.6			8.8	7.4/34.8m		34.0
36.0			7.2			8.3	6.9		36.0
38.0			6.7			8.1/36.7m	6.6		38.0
40.0			6.3				6.2		40.0
42.0			5.8/41.9m	3.8/43.7m			5.8		42.0
44.0				3.8			5.4	3.4/45.8m	44.0
46.0				3.7			5.2/44.8m	3.4	46.0
48.0				3.4				3.3	48.0
50.0					3.1/49.4m			3.1	50.0
52.0								2.9	52.0
54.0								2.8/52.4m	54.0
56.0									56.0
58.0									58.0
60.0									60.0

(単位:t)

タワー長さm	48.6																タワー長さm									
ジブ長さm	29.0				32.0				35.1				38.1				41.1				44.2				ジブ長さm	
タワー角度	90°	80°	70°	60°	90°	80°	70°	60°	90°	80°	70°	60°	90°	80°	70°	60°	90°	80°	70°	90°	80°	70°	60°	タワー角度		
9.4																									9.4	
10.0	20.0/11.0m				19.9/11.8m																				10.0	
12.0	20.0				19.9				16.5/12.5m				13.6/13.3m												12.0	
14.0	19.5				18.6				16.2				13.6		10.7/14.1m					9.1/14.9m					14.0	
15.0	18.9				18.0				15.9				13.3		10.7					9.1					15.0	
16.0	18.3				17.5				15.7				13.1		10.5					8.9					16.0	
18.0	16.6				16.5				15.2				12.7		10.1					8.6					18.0	
20.0	15.0				15.0				14.8				12.3		9.8					8.3					20.0	
22.0	13.6				13.6				13.6				11.9		9.5					8.0					22.0	
24.0	12.5	12.4/24.1m			12.5	11.9/25.4m			12.5				11.5		9.2					7.7					24.0	
26.0	11.4	11.5			11.5	11.5			11.5	11.2/26.7m			11.1		8.9					7.4					26.0	
28.0	9.4	10.7			10.3	10.7			10.7	10.7			10.5	10.7	8.6	9.8/29.3m			7.2						28.0	
30.0	7.3	10.0			8.7	10.0			9.4	10.0			9.6	10.0	8.3	9.6			6.9	8.0/30.6m					30.0	
32.0	6.5/31.2m	9.3			7.1	9.3			8.1	9.3			8.5	9.3	7.8	9.2			6.7	7.8					32.0	
34.0		8.8			5.2	8.8			6.7	8.8			7.4	8.8	7.3	8.8			6.4	7.6					34.0	
36.0		8.3	6.8/36.8m		4.8/34.2m	8.3			5.3	8.3			6.3	8.3	6.8	8.3			6.0	7.3					36.0	
38.0		7.8	6.3		7.8	6.2/38.3m			4.1/37.1m	7.8			5.1	7.8	6.2	7.8			5.6	7.1					38.0	
40.0		7.1/39.7m	6.0		7.3	5.8			7.5	5.7/40.1m			3.8	7.5	5.2/41.8m	5.2	7.3		5.2	6.9					40.0	
42.0			5.6		6.7	5.5			7.1	5.3			3.5/40.1m	6.9	5.2	4.1	6.8	4.8/43.6m	4.8	6.7					42.0	
44.0			5.3		6.2/42.6m	5.2			6.5	5.1				6.5	5.0	3.2/43.0m	6.4	4.7	4.0	6.2	4.4/45.3m				44.0	
46.0			5.0			4.9			5.4/45.6m	4.8				6.0	4.7		5.9	4.6	2.8	5.8	4.3				46.0	
48.0			4.5/47.8m		3.1				4.6					5.5	4.4		5.5	4.3		5.5	4.1				48.0	
50.0				3.0		4.3	2.7/50.1m		4.2					4.7/48.5m	4.1		5.1	4.0		5.1	3.9				50.0	
52.0				2.8		4.0/50.7m	2.6		4.0	2.4/52.3m				3.8		4.3/51.4m	3.7			4.7	3.6				52.0	
54.0				2.6			2.5			3.5/53.7m	2.3			3.6			3.5			4.3	3.4				54.0	
56.0				2.4/55.3m			2.4				2.2			3.4			3.3			3.8/54.4m	3.1				56.0	
58.0							2.2				2.1			3.3/56.6m			3.0				2.9				58.0	
60.0								2.1/58.3m			2.0						2.8/59.6m				2.7				60.0	
62.0																					2.5				62.0	
64.0																					2.4/62.5m					64.0

*表中の太線で囲まれた部分は、ブーム等の強度によって定められた値です。

▶タワー長さ 51.7m

(単位:t)

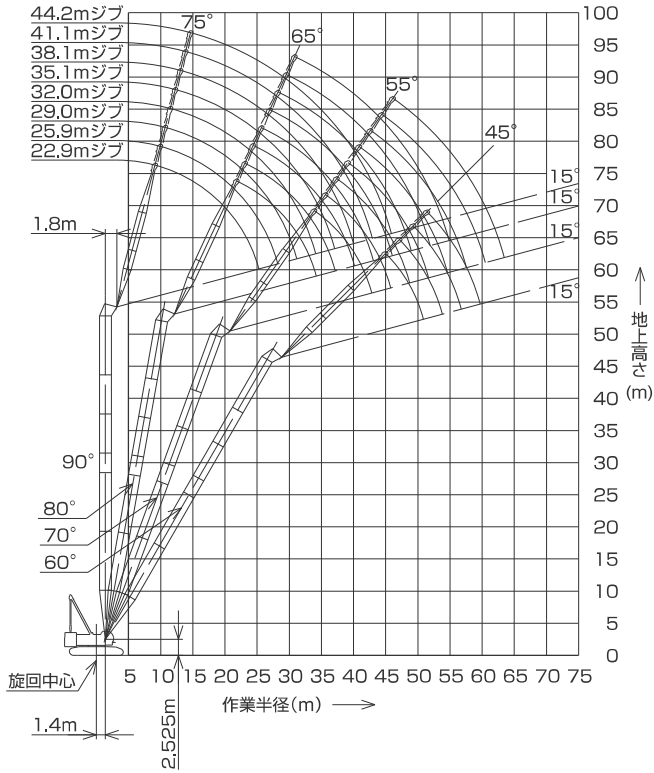

タワー長さm	51.7								タワー長さm
ジブ長さm	22.9				25.9				ジブ長さm
タワー角度	90°	80°	70°	60°	90°	80°	70°	60°	タワー角度
9.4	20.0								9.4
10.0	20.0				20.0/10.2m				10.0
12.0	20.0				20.0				12.0
14.0	20.0				19.2				14.0
15.0	20.0				18.6				15.0
16.0	18.7				18.1				16.0
18.0	16.6				16.6				18.0
20.0	15.0				15.0				20.0
22.0	13.6	13.5/22.1m			13.6	12.8/23.4m			22.0
24.0	10.4	12.5			12.5	12.5			24.0
26.0	7.6/25.4m	11.5			10.0	11.5			26.0
28.0		10.7			7.2	10.7			28.0
30.0		10.0			28.3m/6.5	10.0			30.0
32.0		9.3				9.3			32.0
34.0		8.8	7.3/34.1m			8.8	6.6/35.9m		34.0
36.0		6.7/34.3m	6.7			8.3	6.5		36.0
38.0			6.3			8.2/37.3m	6.2		38.0
40.0			5.9				5.8		40.0
42.0			5.5				5.4		42.0
44.0			5.2/42.9m	3.3/45.2m			5.1		44.0
46.0				3.2			4.8/45.9m	3.0/47.3m	46.0
48.0				3.1				2.9	48.0
50.0				2.9				2.8	50.0
52.0				2.8/51.0m				2.6	52.0
54.0								2.4/53.9m	54.0
56.0									56.0
58.0									58.0

(単位:t)

タワー長さm	51.7																		タワー長さm	
ジブ長さm	29.0			32.0			35.1			38.1			41.1			44.2			ジブ長さm	
タワー角度	90°	80°	70°	60°	90°	80°	70°	60°	90°	80°	70°	90°	80°	70°	90°	80°	70°	タワー角度		
9.4																		9.4		
10.0	20.0/11.0m				18.8/11.8m													10.0		
12.0	19.4				18.6				16.5/12.5m			13.6/13.3m						12.0		
14.0	18.2				17.4				16.2			13.6		10.7/14.1m			9.1/14.9m	14.0		
15.0	17.7				16.8				15.9			13.3		10.7			9.1	15.0		
16.0	17.2				16.4				15.6			13.1		10.5			8.9	16.0		
18.0	16.3				15.5				14.7			12.6		10.1			8.6	18.0		
20.0	15.0				14.7				14.0			12.2		9.8			8.3	20.0		
22.0	13.6				13.6				13.4			11.9		9.5			8.0	22.0		
24.0	12.5	12.1/24.7m			12.5	11.5/25.9m			12.5			11.5		9.1			7.7	24.0		
26.0	11.4	11.5			11.5	11.5			11.5	10.7/27.2m		11.1		8.9			7.4	26.0		
28.0	9.4	10.7			10.3	10.7			10.7	10.3		10.4	10.0/28.5m	8.6	8.5/29.8m		7.1	28.0		
30.0	7.3	10.0			8.7	10.0			9.4	9.9		9.6	9.1	8.3	8.5		6.9	8.0/31.1m	30.0	
32.0	5.5/31.2m	9.3			7.1	9.3			8.1	9.3		8.5	8.8	7.8	8.2		6.7	7.6	32.0	
34.0		8.8			5.2	8.8			6.8	8.8		7.4	8.5	7.3	7.9		6.4	7.3	34.0	
36.0		8.3	6.0/37.6m		4.8/34.2m	8.3			5.3	8.3		6.3	8.2	6.8	7.6		6.0	7.1	36.0	
38.0		7.6	5.9		7.8	5.4/39.4m			4.2/37.1m	7.8		5.2	7.7	6.3	7.4		5.6	6.8	38.0	
40.0		6.9	5.7		7.4	5.4			7.3	4.9/41.1m		3.8	7.1	5.2	7.0		5.2	6.6	40.0	
42.0		6.8/40.2m	5.3		6.8	5.2			6.8	4.9	3.5/40.1m	6.6	4.4/42.9m	4.1	6.5		4.8	6.4	42.0	
44.0			5.0		6.2/43.1m	4.9			6.3	4.8		6.2	4.4	3.2/43.0m	6.1	4.2/44.6m	4.0	5.9	44.0	
46.0			4.7			4.6			5.7	4.5		5.7	4.3		5.7	4.0	2.8	5.5	3.8/46.4m	46.0
48.0			4.4	2.6/49.5m		4.3			5.4/46.1m	4.2		5.3	4.0		5.3	3.8		5.2	3.6	48.0
50.0			4.2/48.8m	2.6		4.0	2.2/51.6m		3.9		4.7/49.0m	3.7		4.9	3.6		4.8	3.4	50.0	
52.0				2.5		3.7/51.8m	2.2		3.6			3.5		4.3	3.3		4.5	3.2	52.0	
54.0				2.3			2.1		3.4			3.2					4.2	3.0	54.0	
56.0				2.1			2.0		3.3/54.7m			3.0					3.8/54.9m	2.8	56.0	
58.0				2.0/56.8m								2.8/57.6m					2.7	2.6	58.0	
60.0																	2.5	2.4	60.0	
62.0																	2.4/60.8m	2.2	62.0	
64.0																			2.0/63.5m	64.0

※表中の太線で囲まれた部分は、ブーム等の強度によって定められた値です。

●クローラークレーン●

■分解時の寸法・質量

- 記載の数値は参考値です。
- 一般公道での輸送に際しては関係法規を遵守してください。

■本体

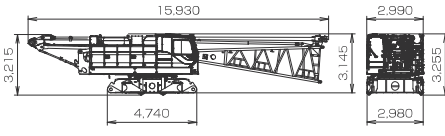
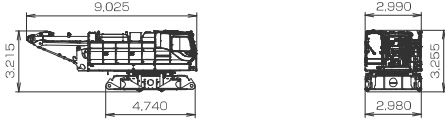
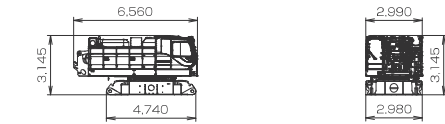
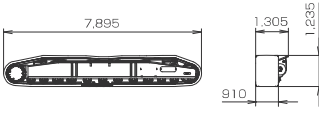
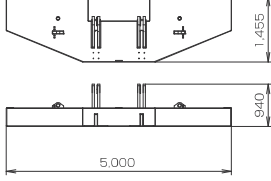
名称	寸法 mm	質量 kg
本体 ・下部ブーム ・ガントリ ・クレーンバックストップ ・ワイヤロープ (主巻、補巻、ブーム起状) 付 ・クローラなし		34,800
本体 ・ガントリ ・ワイヤロープ (主巻、補巻、ブーム起状) 付 ・クローラなし		31,000
本体 ・ガントリなし ・ワイヤロープなし (主巻、補巻ドラム) ・トランスリフタなし ・クローラなし		25,400
クローラ		14,500
カウンタウエイト (1)		9,800

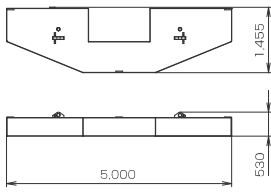
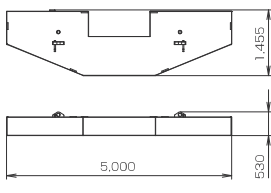
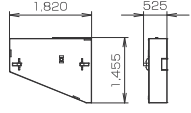
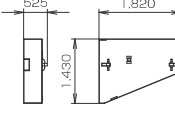
名称	寸法 mm	質量 kg
カウンタウエイト (2)		9,610
カウンタウエイト (3)		9,700
カウンタウエイト (4L, 5L, 6L)		4,000
カウンタウエイト (4R, 5R, 6R)		4,000

●クローラークレーン●

▶アタッチメント (ガイドラインの質量は含まれていません)

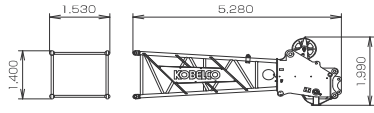
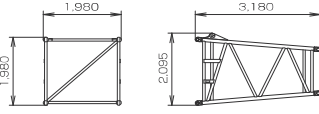
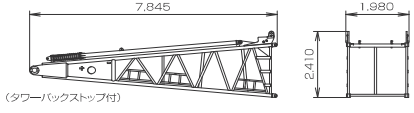
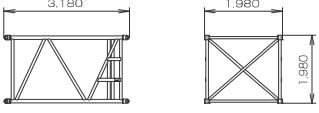
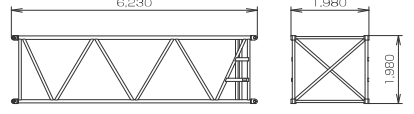
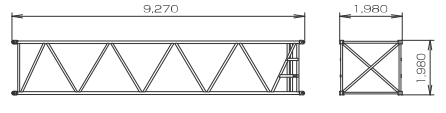
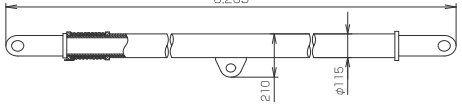
名称	寸法 mm	質量 kg
上部ブーム		1,850
中間テーパーブーム		490
下部ブーム	 (タワーバックストップ付)	3,100
3.0m中間ブーム		530
6.1m中間ブーム		850
9.1m中間ブーム		1,160
クレーンバックストップ		210/片割

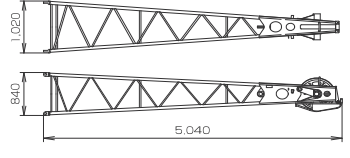
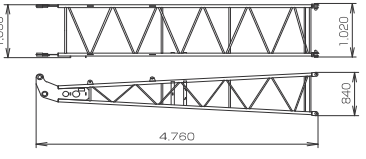
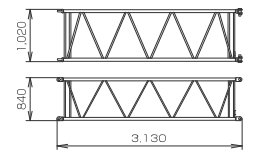
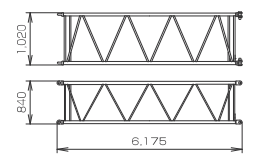
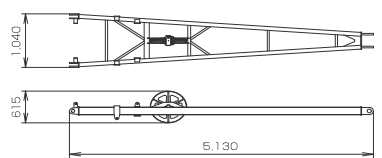
名称	寸法 mm	質量 kg
上部ジブ		315
下部ジブ		210
3.0m中間ジブ		110
6.1m中間ジブ		190
クレーンジブストラット		300

●クローラークレーン●

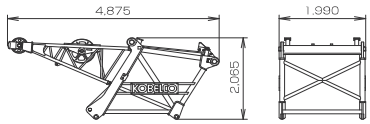
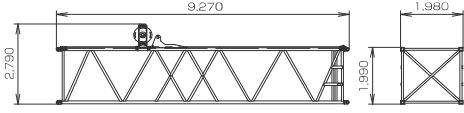
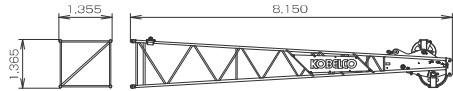
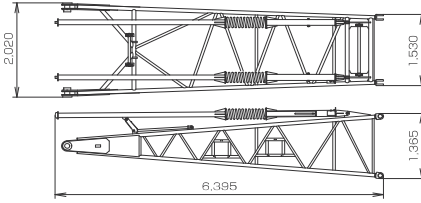
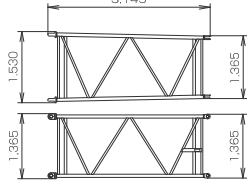
名称	寸法 mm	質量 kg
タワーキャップ		1,780
9.1m (9.1A) 特殊中間 タワーブーム (上面足場含む)		1,540
上部タワージブ		900
下部タワージブ		1,200
3.0m (3.0A) 特殊中間 タワージブ (特殊中間ブーム)		230

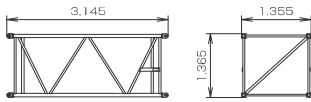
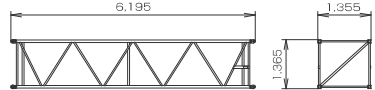
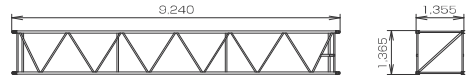
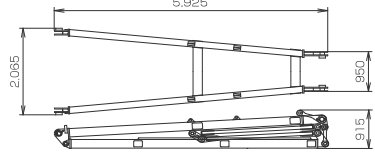
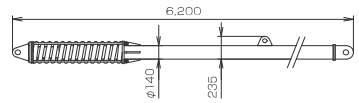
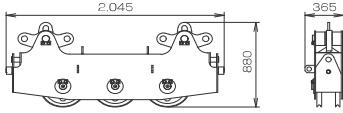
名称	寸法 mm	質量 kg
3.0m中間タワージブ		210
6.1m中間タワージブ		360
9.1m中間タワージブ		510
タワージブストラット		1,355
タワーバックストップ		420/片側
クレーン上部スプレッド		485

●クローラークレーン●

名称	寸法 mm	質量 kg
クレーン下部スレッド		315
タワー上部スレッド		310
タワー下部スレッド		410
120tフック		1,700

名称	寸法 mm	質量 kg
70tフック		1,200
35tフック		900
ボールフック		450