

700t

TADANO
AR-7000N-1

構成図

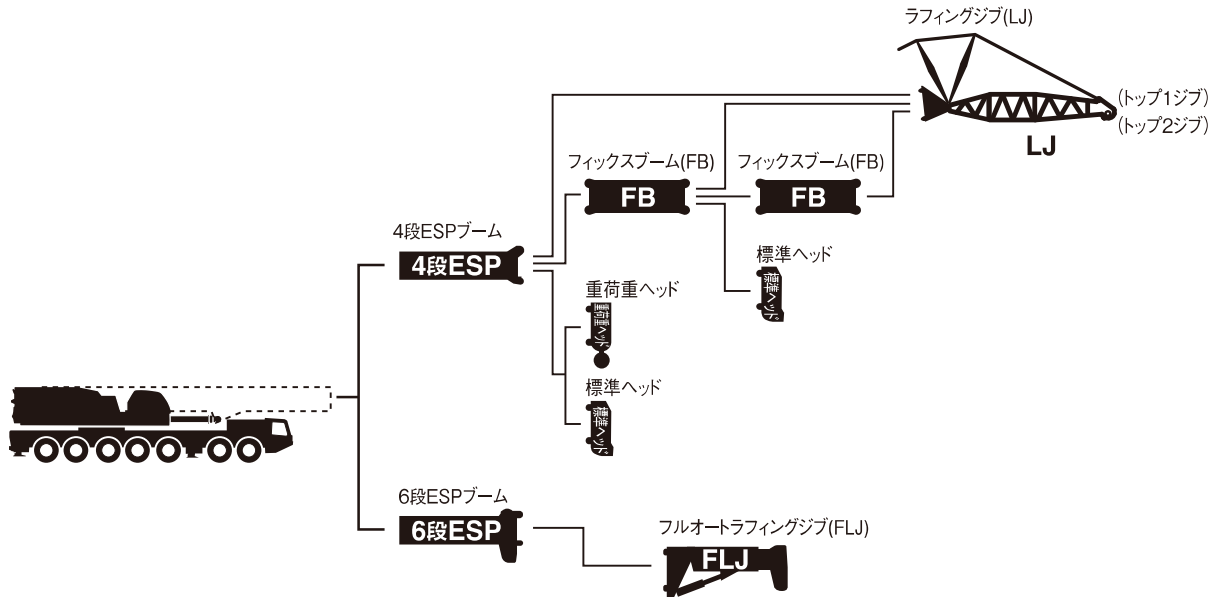

- ・ AR-7000Nは4段ESPブーム、6段ESPブームの2種類のブームがあります。
- ・ フィックスブーム(FB)、ラフィングジブ(LJ)は4段ESPブームに取り付けます。
- ・ 4段フルオートラフィングジブ(FLJ)は6段ESPブームに取り付けます。
- ・ 組合せはINDEX、定格総荷重表を参照してください。

INDEX

■ 諸元	・ クレーン、キャリア	P 2
■ 走行	・ 公道走行状態、構内移動姿勢	P 4
	・ 最小直角通路幅	P 5
■ 搬送	・ 分解搬送部品	P 6
■ 設置	・ アウトリガ張出幅・テールスイング	P 10
	・ フック寸法(4段ESP、6段ESP、LJ、FLJ)、カウンタウエイト組合せ	P 11
■ 定格総荷重表	・ 4段ESPブーム・フィックスブーム(FB)	P 13
	・ ラフィングジブ(LJ)	P 19
	・ 6段ESPブーム	P 35
	・ フルオートラフィングジブ(FLJ)	P 41

諸 元

■ クレーン

4段ESPブーム、フィックスブーム(FB)、ラフィングジブ(LJ)		
4段ESPブーム(4段ESP)	15.4m	700,000 kg × 2.7m (36本掛×2)
	20.0m	330,000 kg × 5.0m (16本掛×2)
	24.6m	330,000 kg × 5.0m (16本掛×2)
	29.2m	268,000 kg × 7.0m (12本掛×2)
	33.8m	268,000 kg × 6.0m (12本掛×2)
	38.4m	200,000 kg × 9.0m (10本掛×2)
	43.0m	157,000 kg × 12.0m (14本掛)
	シングルトップ	12,500 kg (1本掛)
4段ESPブーム + フィックスブーム(FB)	37.1m	170,000 kg × 12.0m (16本掛)
ラフィングジブ(LJ)	18m LJ	140,000 kg × 14.0m (12本掛)
	27m LJ	118,500 kg × 14.0m (10本掛)
	36m LJ	84,800 kg × 16.0m (8本掛)
	45m LJ	59,200 kg × 22.0m (6本掛)
	54m LJ	43,300 kg × 30.0m (4本掛)
	63m LJ	25,000 kg × 50.0m (2本掛)
	72m LJ	24,000 kg × 34.0m (2本掛)
	81m LJ	17,600 kg × 55.0m (2本掛)
90m LJ	10,300 kg × 46.0m (2本掛)	
最大地上揚程	4段ESP	42.7m (157 t)
	4段ESP+FB	55.1m (120.8 t)
最大作業半径	LJ	140.5m (5.7 t)
	4段ESP	40.0m (29.8 t)
最大作業半径	4段ESP+FB	52.0m (16.1 t)
	LJ	110.0m (3.7 t)
ブーム・ジブ長さ	4段ESP	14.9m ~ 42.5m + 0.5mヘッド
	FB	12.5m
	LJ	2.5m + 18m、27m、36m、45m、54m、63m、72m、81m、90m
ブーム伸長速度	4段ESP	27.6m/410s
ブーム・ジブ形式	4段ESP	箱型4段油圧伸縮式、各段ピンロック方式 重荷重ヘッド/標準ヘッド付替式
	FB	箱型固定式1本
	LJ	ラチス型
ブーム伸縮装置	4段ESP	複動油圧シリンダ直押し1本 圧力補償付流量調整弁付
シングルトップ		ピン結合式

6段ESPブーム、フルオートラフィングジブ(FLJ)		
6段ESPブーム(6段ESP)	15.0m	300,000 kg × 7.0m (14本掛×2)
	19.5m	250,000 kg × 8.0m (12本掛×2)
	24.0m	250,000 kg × 8.0m (12本掛×2)
	28.5m	195,000 kg × 10.0m (18本掛)
	33.0m	195,000 kg × 10.0m (18本掛)
	37.6m	170,000 kg × 11.0m (16本掛)
	42.1m	157,000 kg × 12.0m (14本掛)
	46.6m	147,000 kg × 10.0m (13本掛)
	51.1m	119,600 kg × 12.0m (11本掛)
	55.6m	94,200 kg × 14.0m (10本掛)
	60.1m	76,400 kg × 14.0m (7本掛)
	64.0m	66,800 kg × 16.0m (7本掛)
シングルトップ	12,500 kg (1本掛)	
フルオートラフィングジブ(FLJ)	11.1m FLJ	48,600 kg × 16.0m (5本掛)
	19.1m FLJ	27,200 kg × 16.0m (3本掛)
	27.1m FLJ	15,500 kg × 18.0m (2本掛)
	35.1m FLJ	8,600 kg × 24.0m (1本掛)
最大地上揚程	6段ESP	63.3m (66.8 t)
	FLJ	99.9m (6.5 t)
最大作業半径	6段ESP	62.0m (10.3 t)
	FLJ	80.0m (3.3 t)
ブーム・ジブ長さ	6段ESP	15.0m ~ 64.0m
	FLJ	1.7m + 11.1m ~ 35.1m
ブーム伸長速度	6段ESP	49.0m/560s
	6段ESP	箱型6段油圧伸縮式、各段ピンロック方式
ブーム・ジブ形式	FLJ	六角箱型4段油圧伸縮式、 (2段目順次、3段・4段目同時) オフセット0° ~ 40° 油圧無段階傾斜式
	6段ESP	複動油圧シリンダ直押し1本 圧力補償付流量調整弁付
ブーム・ジブ伸縮装置	FLJ	複動油圧シリンダ直押し2本 ワイヤロープ式伸縮装置1基
	シングルトップ	先端ブーム取付横折曲格納式

諸 元

フック	350 tフック (36本掛) (アタッチメント付) 150 tフック (14本掛) 80 tフック (7本掛) 25 tフック (3本掛) 12.5 tフック (1本掛)	
ワイヤロープ	主巻 径25mm × 長さ705m、非自転性ワイヤロープ 補巻 径25mm × 長さ705m、非自転性ワイヤロープ	
巻上装置	油圧可変モータ駆動遊星歯車減速式 自動ブレーキ 高低速切換装置付 シングルウィンチ 2基 圧力補償付流量調整弁付	
巻上速度	主巻 155m/min (5層) 補巻 155m/min (5層)	
ブーム起伏装置	複動油圧シリンダ直押し3本 圧力補償付流量調整弁付	
ブーム上げ速度	-1.0° ~ 82° / 210s	
旋回装置	油圧モータ駆動遊星歯車減速式 ローラー式スイングベアリング ディスク式ネガティブブレーキ 高低速切換および微速操作装置付	
旋回角度	360°連続	
旋回速度	1.0min ⁻¹ / 0.5min ⁻¹ / 0.3min ⁻¹	
カウンタウエイト	208t、195t、164t、127t、94t、57t、27t	
アウトリガ	全油圧式H型3段 張出幅:最大9.0m、中間8.0m、7.0m、5.8m 最小2.6m 張出幅検出装置付、スライド・ジャッキ各個操作装置付	
センタージャッキ	油圧式 1基	
アシストジャッキ	油圧式 4基	
上部エンジン	形 式	ベンツ OM936LA 水冷4サイクル直列6気筒直接噴射式 排気ターボ過給 インタークーラ付 ディーゼルエンジン 尿素SCRシステム付
	総排気量	7.7L
	最高出力	260kW {354PS} / 2,200min ⁻¹ {rpm}
	最大トルク	1,400N・m {143kgf・m} / 1,200~1,600min ⁻¹ {rpm}
燃料タンク容量	300L	
Adblueタンク容量	25L	
油圧ポンプ	高圧可変ピストンポンプ 2個 高圧ピストンポンプ 1個 高圧ギヤポンプ 1個	
作動油タンク容量	上部 2,279L、下部 270L	
安全装置	過負荷防止装置 (AML) 作業範囲制限機能 フック移動量表示機能 旋回範囲制御機能 旋回自動停止機能 ブーム起伏停止機能 個別検出式アウトリガ張出自動検出装置 カウンタウエイト組合せ検出装置 巻過防止装置 捨巻確保装置 玉掛けロープはずれ止め 油圧安全弁 油圧ロック装置 (起伏、伸縮、巻上げ、ジャッキ) 旋回ロック装置 水準器	
付属装置	ブーム着脱装置 旋回台着脱装置 カウンタウエイト着脱装置 オイルクーラー AML外部表示灯 旋回音声警報装置 拡声器 リモコンサーチライト 風速計 ドラム視認モニタ キャブチルト式クレーン運転室 ブーム起伏微速モード設定装置 エアコン ラジオ 敷鉄板 携帯通信装置 (HELLO-NET Owner's Site)	

■ キャリヤ

メーカー名	Tadano Faun GmbH	
キャリヤ型式	RTF 700-7	
最高速度	62km/h	
登坂能力	tan θ = 0.48	
最小回転半径	11.9m	
全長	15,990mm	
全幅	3,000mm	
全高	3,070mm	
軸距	1,650mm+2,850mm+1,700mm+1,650mm +1,800mm+1,650mm	
輪距	2,550mm	
車両総重量	全重量	47,030kg (人員2名)
	前軸	1軸 + 2軸 15,610kg
	後軸	3軸 + 4軸 + 5軸 13,280kg 6軸 + 7軸 18,140kg
乗車定員	2名	
エンジン	型 式	ベンツ OM471LA 水冷4サイクル直列6気筒直接噴射式 排気ターボ過給 インタークーラ付 ディーゼルエンジン 尿素SCRシステム付
	総排気量	12.8L
	最高出力	390kW [530PS] / 1,700min ⁻¹ {rpm}
	最大トルク	2,460N・m {251kgf・m} / 1,300min ⁻¹ {rpm}
燃料タンク容量	600L	
Adblueタンク容量	40L	
変速機形式	フルオートマチック 前進12段、後退2段 副変速機付	
クラッチ形式	トルクコンバータ付、自動ロックアップ機構付	
駆動方式	14×4 14×6、14×8……(デフロック機構付)	
車軸形式	7軸全浮動式	
懸架方式	全輪ハイドロニューマチック、レベリング装置付 サスペンションストローク +149mm、-113mm	
ステアリング	左ハンドル 非常用ステアリングポンプ付2系統式 パワーステアリング 10輪ステアリング	
ブレーキ	主ブレーキ	空気式全輪ドラムブレーキ 2系統式
	駐車ブレーキ 非常ブレーキ	4・5・6・7軸 制動スプリング式
	補助ブレーキ	変速機内蔵流体式リターダ エンジンブレーキ 電磁式リターダ
タイヤ	445/95R25 (14輪)	
バッテリー	12V-170 Ah×2個 (24 V)	
付属装置	集中給脂装置 バックモニタ エアコン ラジオ 仮眠用ベッド 携帯通信装置 (HELLO-NET Owner's Site)	

走行

公道走行状態

単位(mm)

● キャリヤ 47.03 t

(公道走行時の注意事項)

1. ブーム・起伏装置・旋回体・カウンタウエイト装置およびアウトリガ装置を別送し、クレーン台車のみで走行しなければなりません。
2. 道路運送車両の保安基準による保安基準緩和の認定が必要です。
3. 道路法による特殊車両の通行許可が必要です。基本通行条件 重量：C が記載された適合証明書を取得していますが、実際の通行経路で申請して許可された条件にしたがって走行しなければなりません。

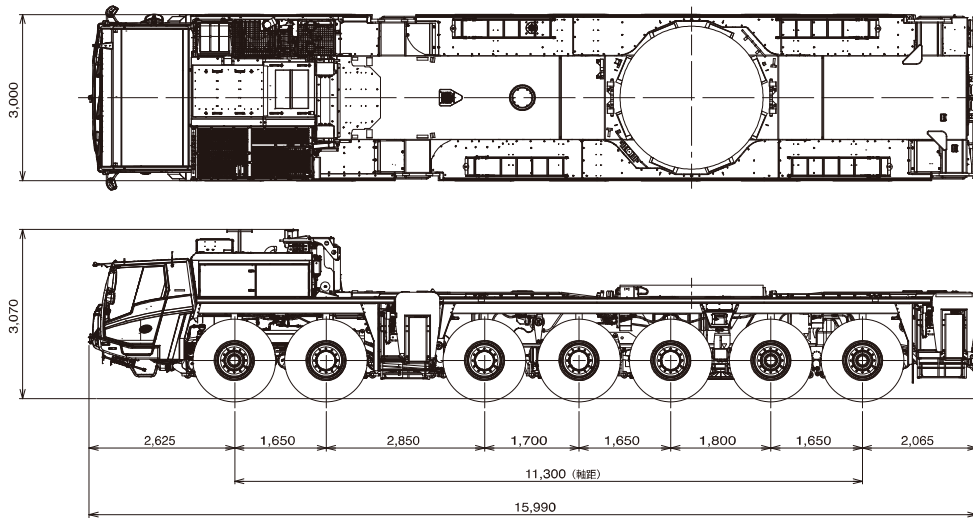

構内移動姿勢 (4段ESP)

単位(mm)

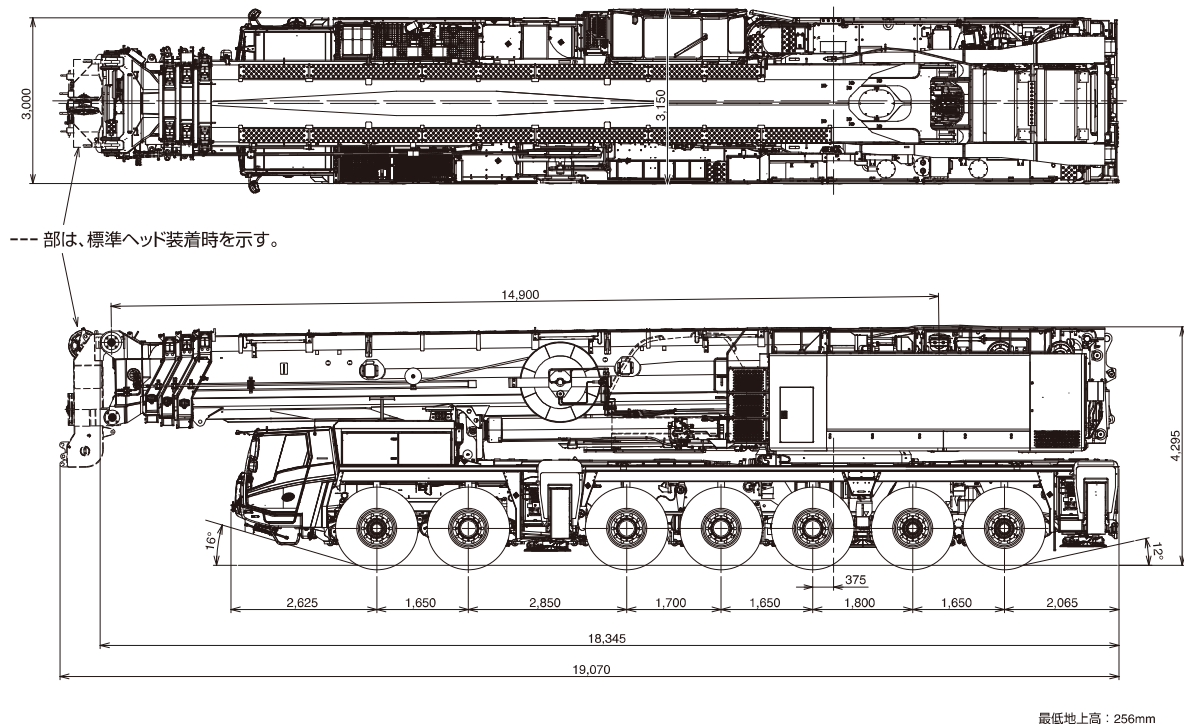

走行

■ 構内移動姿勢 (6段ESP)

単位(mm)

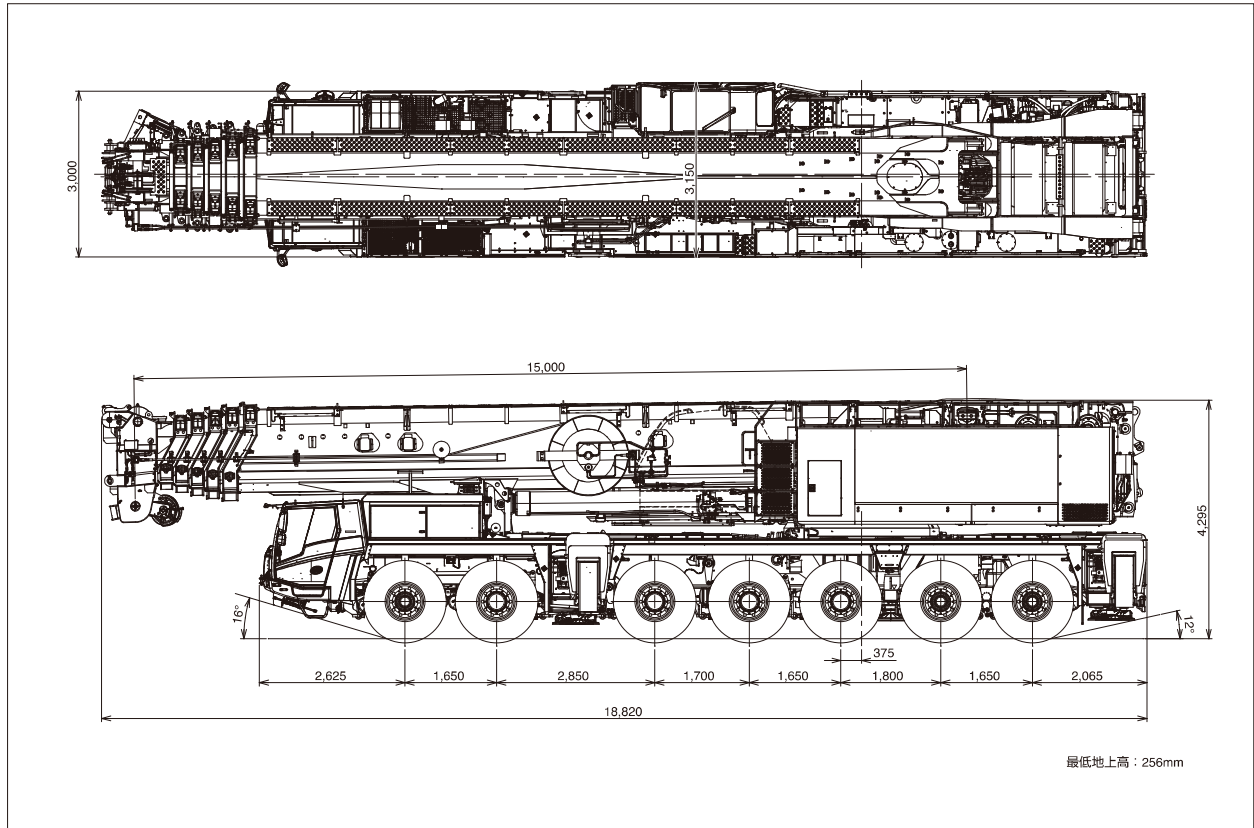

最低地上高：256mm

■ 最小直角通路幅

単位(mm)

● 公道走行状態

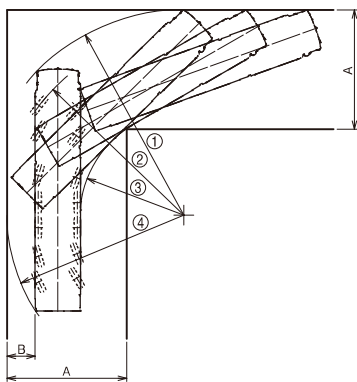

①	13,480
②	11,900
③	6,770
④	11,585
A	7,840
B	1,825

● 構内移動姿勢(4段ESP付 標準ヘッド)

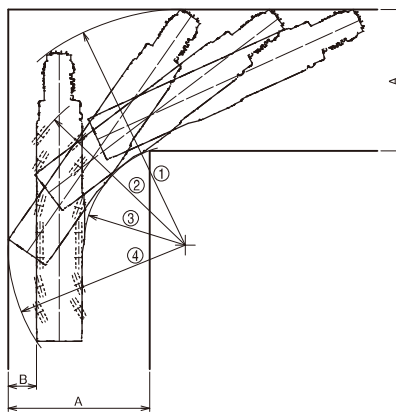

	4段ESP付(標準ヘッド)	4段ESP付(ヘッド無)
①	15,485	15,105
②	11,900	11,900
③	6,630	6,630
④	11,625	11,625
A	9,280	9,010
B	1,860	1,860

● 構内移動姿勢(6段ESP付)

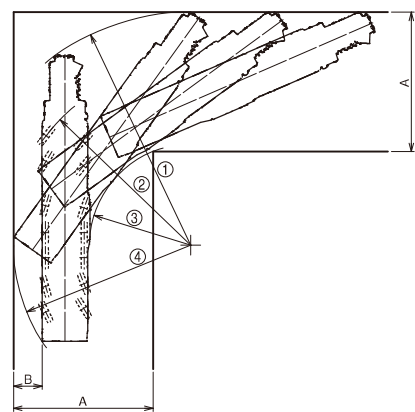

	6段ESP付
①	15,305
②	11,900
③	6,630
④	11,625
A	9,150
B	1,860

搬 送

■ 分解搬送部品

単位(mm)

● 旋回台部 35.3 t

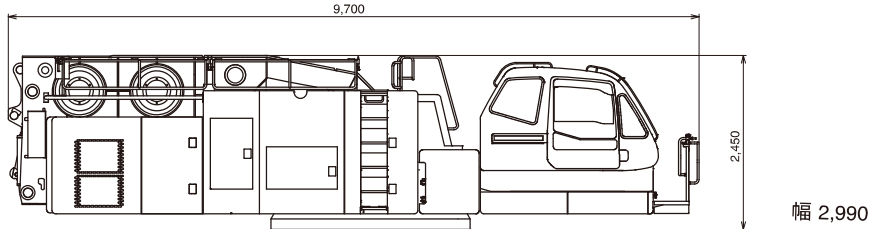

● 起伏シリンダ 7.7 t

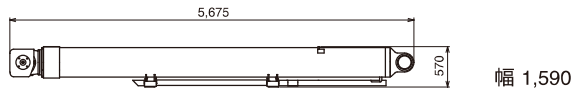

● カウンタウエイト (C/W)

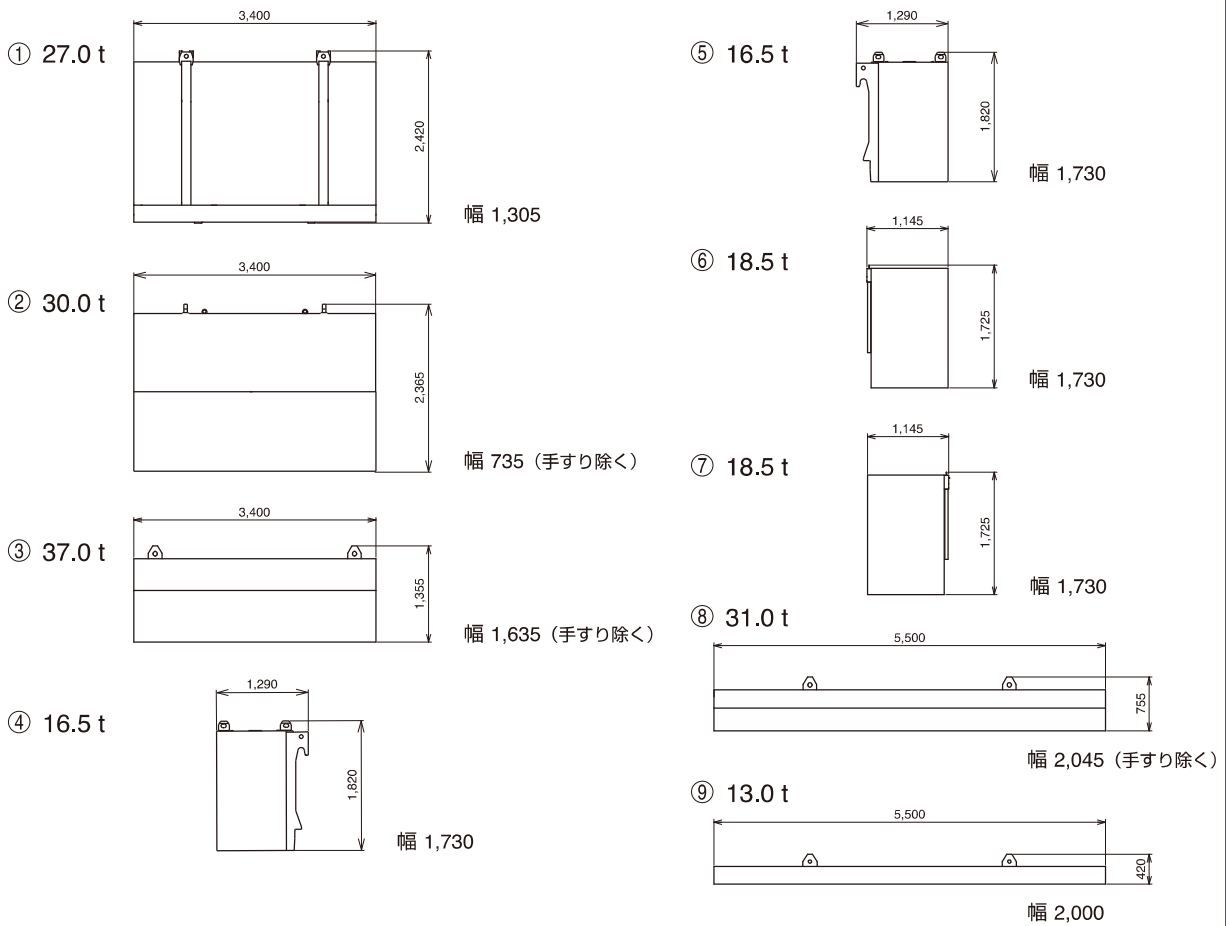

● アウトリガ (O/R)

フロント 3.2 t × 2個
リヤ 3.2 t × 2個

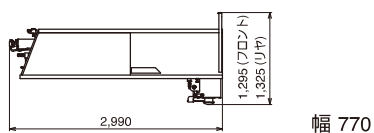

● アシストジャッキ (AJ)

フロント 0.6 t × 2個
リヤ 0.6 t × 2個

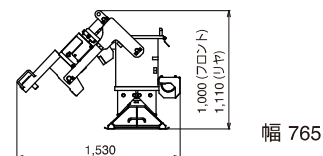

その他に付属品があります。

搬 送

■ 分解搬送部品

単位(mm)

- 4段ESPブーム 44.3 t

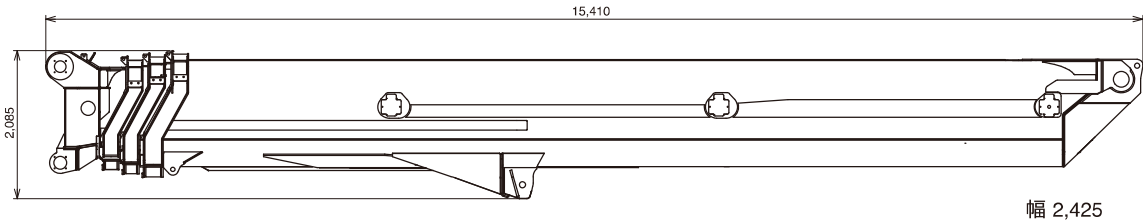

- フィックスブーム (FB) 10.0 t × 2個

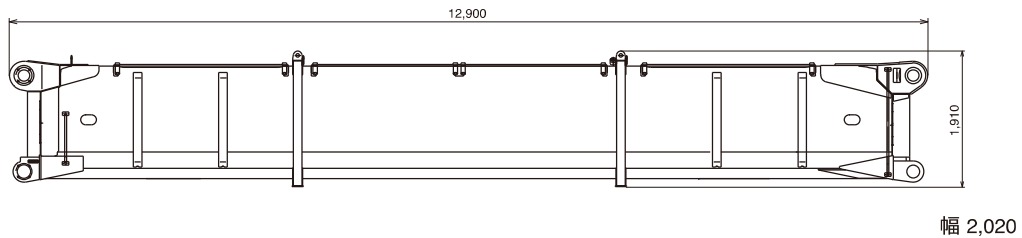

- 標準ヘッド 2.1 t

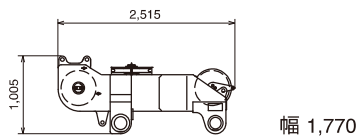

- 重荷重ヘッド 5.5 t

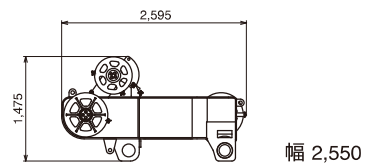

- 6段ESPブーム 46.2 t

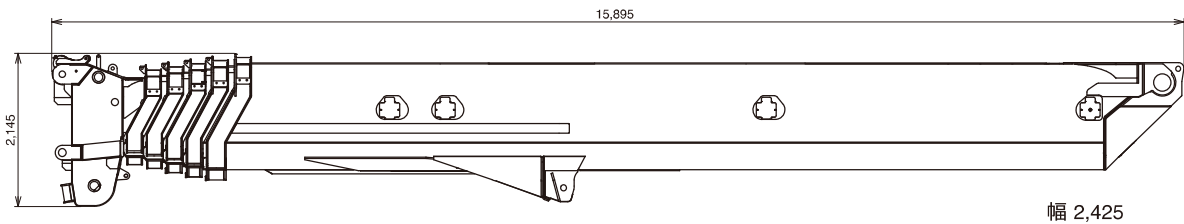

- フルオートラフィングジブ (FLJ) 11.0 t

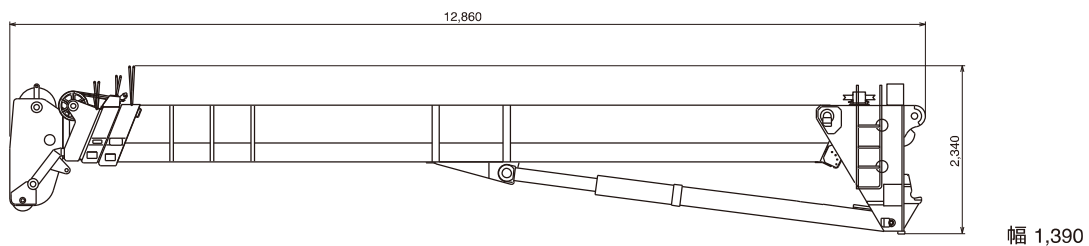

その他に付属品があります。

搬送

■ 分解搬送部品

単位(mm)

● ラフィングジブ (LJ)

マスト 5.3 t

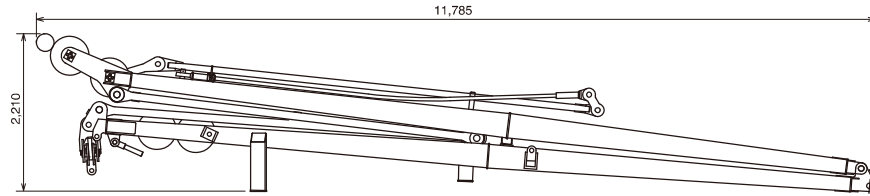

幅 2,125

ベースジブ
+
オーバートップ 7.7 t

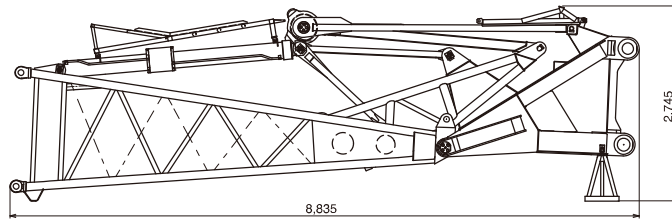

幅 2,260

ミドル1ジブ 1.4 t

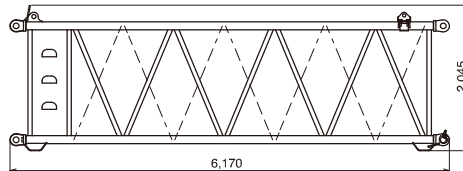

幅 2,160

ミドル2ジブ 2.0 t × 3個

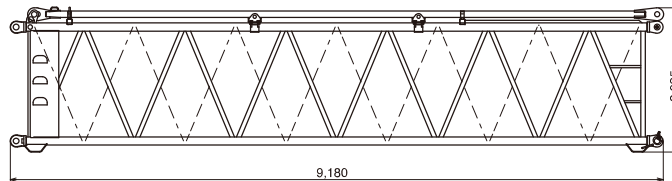

幅 2,160

ミドル2+boss ジブ 2.0 t

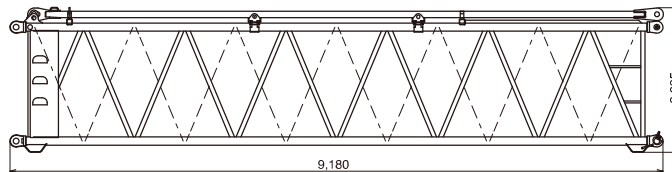

幅 2,160

レデューサジブ 2.1 t

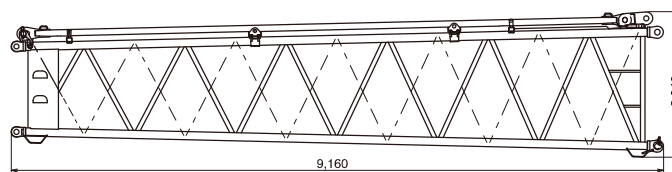

幅 2,160

ミドル3ジブ 1.6 t × 2個

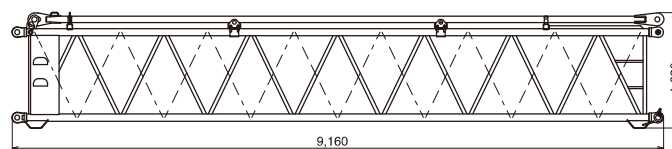

幅 1,760

ミドル3+boss ジブ 1.6 t

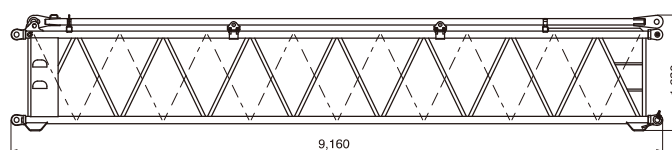

幅 1,760

その他に付属品があります。

搬 送

■ 分解搬送部品

単位(mm)

● ラフィングジブ (LJ)

トップ1ジブ 2.6 t

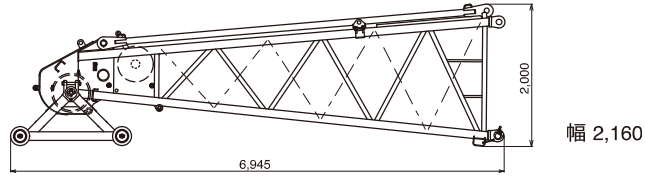

トップ2ジブ 1.9 t

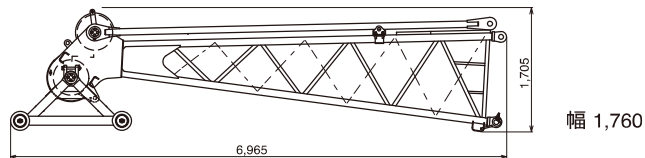

エコライザシーブ 0.6 t

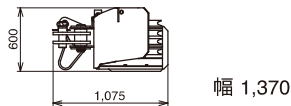

アシストカー 1.5 t (#GF001~ #GF011)

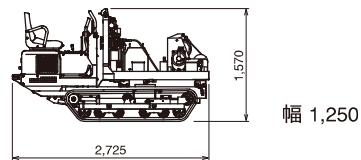

根元シーブ 0.6 t

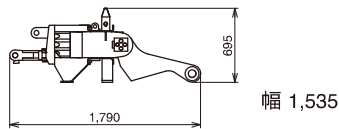

アシストカー 1.7 t (#GF012~)

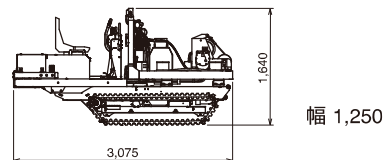

● フック

350tフック 3.46 t × 2個

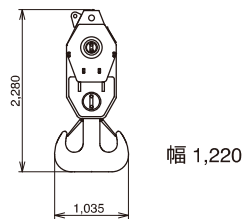

150tフック 2.40 t

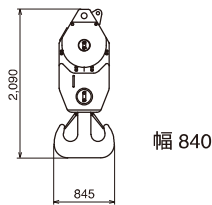

80tフック 1.87 t

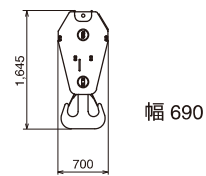

25tフック 1.20 t

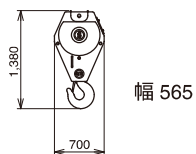

12.5tフック 0.50 t

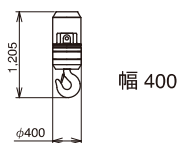

その他に付属品があります。

設 置

■ フック寸法

H: ヘッドシーブ中心とハッカ上面の距離

		350t×2 フック		350tフック		150t フック
		アタッチメント 付	アタッチメント 無	アタッチメント 付	アタッチメント 無	
4段ESP	重荷重ヘッド	7.4m	5.2m		5.2m	
	標準ヘッド					3.2m
6段ESP				5.2m	3.4m	3.3m

		350t フック	150t フック	80t フック	25t フック	12.5t フック
		4段ESP 6段ESP	シングルトップ			
	LJ (トップ1)	4.2m	4.1m	3.9m		
	LJ (トップ2)				3.5m	
	FLJ			3.7m	3.0m	3.8m

■ カウンタウエイト(C/W)組合せ

● 各ウエイトの使用個数を示す

合計 重量	ウエイト ① 27t	ウエイト ② 30t	ウエイト ③ 37t	ウエイト ④ 16.5t	ウエイト ⑤ 16.5t	ウエイト ⑥ 18.5t	ウエイト ⑦ 18.5t	ウエイト ⑧ 31t	ウエイト ⑨ 13t
208 t	1	1	1	1	1	1	1	1	1
195 t	1	1	1	1	1	1	1	1	
164 t	1	1	1	1	1	1	1		
127 t	1	1	1	1	1				
94 t	1	1	1						
57 t	1	1							
27 t	1								

208t

195t

164t

127t

94t

57t

27t

4段ESPブーム・フィックスブーム



4段ESPブーム



4段ESPブーム作業半径-揚程図

■ 重荷重ヘッド仕様

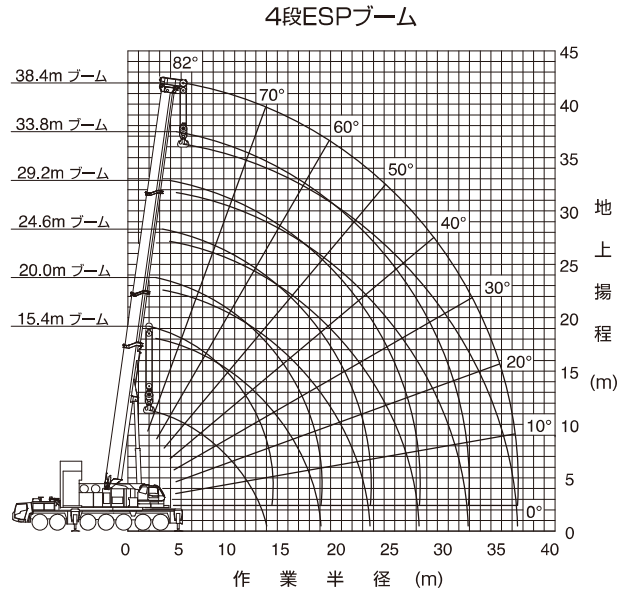

- (注意) 1. 上図はブームのたわみを含んでいません。
2. 重荷重ヘッド装着、カウンタウイト164 t、アウトリガ張出幅9.0m、センタージャッキ、アシストジャッキ使用時の性能を図示しています。
3. ブーム長さは、4段ESPブームと0.5m重荷重ヘッドの合計ブーム長さを示しています。

■ 標準ヘッド仕様

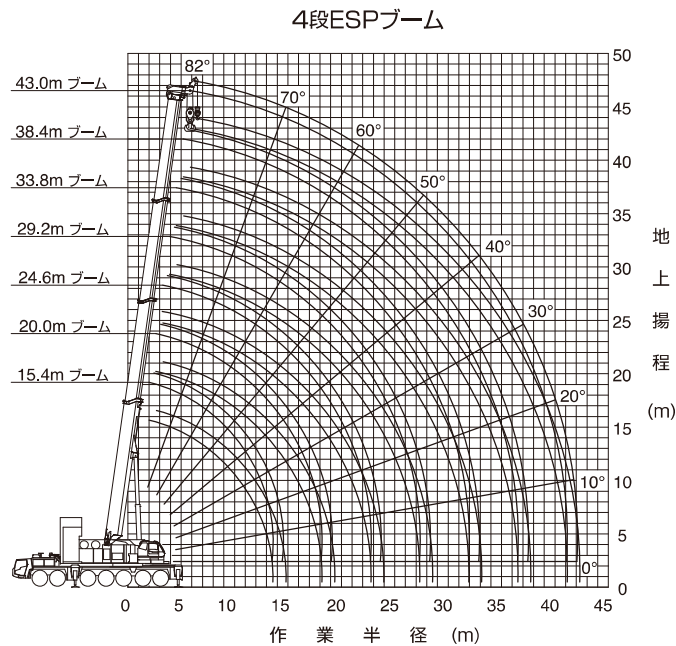

- (注意) 1. 上図はブームのたわみを含んでいません。
2. 標準ヘッド装着、カウンタウイト164 t、アウトリガ張出幅9.0m、アシストジャッキ使用時の性能を図示しています。
3. ブーム長さは、4段ESPブームと0.5m標準ヘッドの合計ブーム長さを示しています。

4段ESPブーム+フィックスブーム



4段ESPブーム+フィックスブーム(FB)作業半径-揚程図

4段ESPブーム+12.5mフィックスブーム(FB)

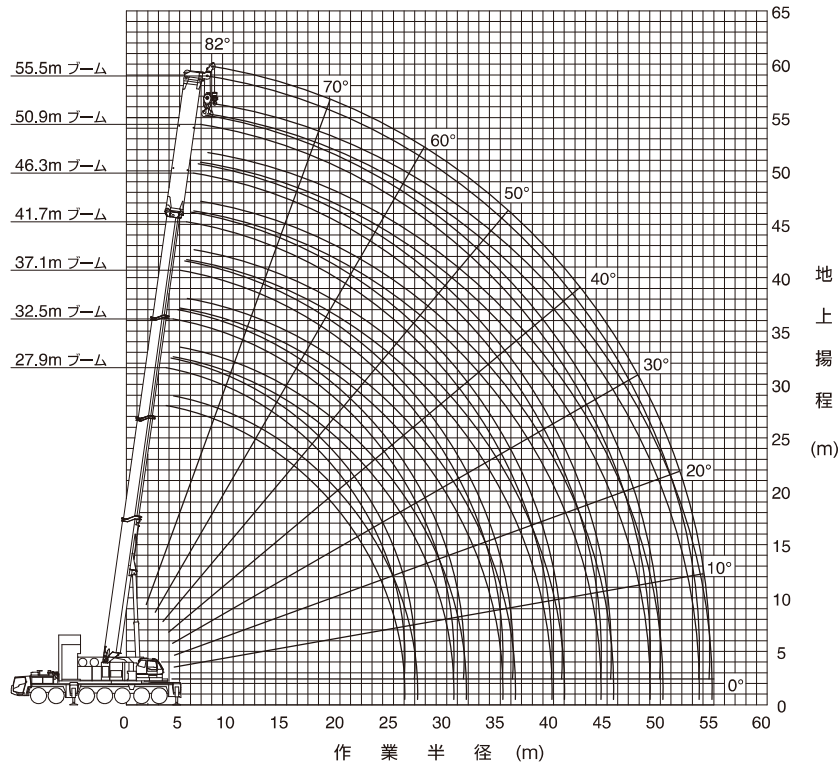

- (注意) 1. 上図はブームのたわみを含んでいません。
 2. 標準ヘッド装着、カウンタウイト164 t、アウトリガ張出幅9.0m、アシストジャッキ使用時の性能を図示しています。
 3. ブーム長さは、4段ESPブーム、12.5mフィックスブーム、0.5m標準ヘッドの合計ブーム長さを示しています。

4段ESPブーム・フィックスブーム

4段ESPブーム、4段ESPブーム+フィックスブーム(FB) 定格総荷重表

■ 定格総荷重表注意事項

- ◆性能設定のあるカウンタウエイトとアウトリガ張出幅の組合せを、下表に○印で示します。
◎印は旋回方向によって性能が異なります。
○印は旋回方向によって性能が異なります。
CJ+AJ付はセンタージャッキ、アシストジャッキを装着している状態を示し、AJ付はアシストジャッキを装着している状態を示します。
本仕様書では、**■**の定格総荷重表のみ記載しています。
また、各ブーム長さにおいて異なる伸縮状態の中から最大になる性能を抜粋し記載しています。
※同じブーム長さでも、ブームの伸長状態によって定格総荷重が異なります。
このため、カウンタウエイトとアウトリガ張出幅の組合せに応じた定格総荷重および他の詳細については、別冊の仕様書を参照してください。

【4段ESPブーム、重荷重ヘッド】

アウトリガ張出幅 \ カウンタウエイト	208 t	195 t	164 t	127 t	94 t	57 t	27 t	0 t
9.0 m (CJ+AJ付)	○	◎ P18	○	○	○	△	△	△
9.0 m (AJ付)	○	○	○	○	○	△	△	○
9.0 m	○	○	○	○	○	△	△	○

【4段ESPブーム、標準ヘッド】

アウトリガ張出幅 \ カウンタウエイト	208 t	195 t	164 t	127 t	94 t	57 t	27 t	0 t
9.0 m (AJ付)	◎ P18	○	○	◎ P18	◎ P18	○	○	○
9.0 m	○	○	○	○	○	○	○	○
8.0 m	△	△	△	○	○	○	○	○
7.0 m	△	△	△	△	○	○	○	○
5.8 m	△	△	△	△	△	○	○	○
2.6 m	△	△	△	△	△	△	△	◎

【4段ESPブーム+フィックスブーム(FB)、標準ヘッド】

アウトリガ張出幅 \ カウンタウエイト	208 t	195 t	164 t	127 t	94 t	57 t	27 t	0 t
9.0 m (AJ付)	◎ P18	○	○	○	○	○	△	○
9.0 m	○	○	○	○	○	○	△	○
8.0 m	△	△	△	○	○	○	△	△
7.0 m	△	△	△	△	○	○	△	△
5.8 m	△	△	△	△	△	○	△	△

- ◆定格総荷重は、つり具質量とフック質量(350tアタッチメント付フック:3,900kg、350tフック:3,460kg、12.5tフック:500kg)を含んだ値を示します。
- ◆定格総荷重は、ブームのたわみを含んだ実際の作業半径に基づいています。
- ◆各状態ごとの標準巻掛本数は別冊の仕様書を参照してください。
- ◆シングルトップ使用時の巻掛本数は1本(12.5tフック使用)で、定格総荷重はブームの定格総荷重からブームに取り付けられているフックの質量を差し引いた値とし、かつ限度は12.5tです。
- ◆定格総荷重は、アウトリガを水平堅土上に設置したときの値です。
- ◆定格総荷重表は、風による影響を含んでいません。瞬間最大風速が10m/s以上の風速では、クレーン作業を中止してください。

4段ESPブーム・フィックスブーム

定格総荷重表中のシンボル、記号の説明

 4段ESP+0.5mHH	4段 ESP (重荷重ヘッド仕様) の定格総荷重を示します。
 4段ESP+0.5mSH	4段 ESP (標準ヘッド仕様) の定格総荷重を示します。
 4段ESP+12.5mFB+0.5mSH	4段 ESP+フィックスブーム (FB) の定格総荷重を示します。
	カウンタウエイト (C/W) 組合せを示します。
	アウトリガ張出幅を示します。
 CJ+AJ	センタージャッキ (CJ)、アシストジャッキ (AJ) を装着している状態を示します。
 AJ	アシストジャッキ (AJ) を装着している状態を示します。
 360°	吊上げ可能な旋回範囲を示します。 360°旋回可能です。
 t JPN	定格総荷重の単位を示します。
 m	ブーム長さを示します。
 m	作業半径を示します。

4段ESPブーム・フィックスブーム



--	--	--	--	--	--

Boom Length (m)	14.9	19.5	24.1	28.7	33.3	37.9	m
合計ブーム長さ	15.4	20.0	24.6	29.2	33.8	38.4	m
2.7	※700.0						2.7
3.0	550.0						3.0
3.5	465.6						3.5
4.0	429.3	330.0					4.0
4.5	398.5	330.0	330.0				4.5
5.0	371.9	330.0	330.0	268.0			5.0
6.0	328.2	319.7	311.5	268.0	268.0		6.0
7.0	293.2	285.8	278.0	268.0	266.1	200.0	7.0
8.0	256.7	258.2	251.0	248.7	243.3	200.0	8.0
9.0	227.7	230.8	231.0	226.7	221.5	200.0	9.0
10.0	204.3	207.1	207.8	208.3	203.3	199.4	10.0
11.0	184.9	187.6	188.2	189.0	187.9	184.0	11.0
12.0	168.7	171.1	171.7	172.5	171.8	170.8	12.0
14.0		144.9	145.6	146.3	145.6	145.1	14.0
16.0		125.1	125.7	126.3	125.6	125.1	16.0
18.0		74.0	110.2	110.7	110.0	109.4	18.0
20.0			97.8	98.1	97.4	96.8	20.0
22.0			70.5	86.6	85.6	84.8	22.0
24.0				76.3	75.3	74.4	24.0
26.0				61.4	66.8	65.9	26.0
28.0					59.9	58.9	28.0
30.0					52.6	52.9	30.0
32.0						47.9	32.0
34.0						43.6	34.0
36.0						30.0	36.0

※は旋回位置が後方限定の性能を示しています。

--	--	--	--	--	--

Boom Length (m)	14.9	19.5	24.1	28.7	33.3	37.9	42.5	m
合計ブーム長さ	15.4	20.0	24.6	29.2	33.8	38.4	43.0	m
3.0	170.0							3.0
3.5	170.0	170.0						3.5
4.0	170.0	170.0	170.0					4.0
4.5	170.0	170.0	170.0					4.5
5.0	170.0	170.0	170.0	170.0				5.0
6.0	170.0	170.0	170.0	170.0	170.0			6.0
7.0	170.0	170.0	170.0	170.0	170.0	170.0		7.0
8.0	170.0	170.0	170.0	170.0	170.0	170.0	157.0	8.0
9.0	170.0	170.0	170.0	170.0	170.0	170.0	157.0	9.0
10.0	170.0	170.0	170.0	170.0	170.0	170.0	157.0	10.0
11.0	145.9	148.7	150.2	150.7	149.8	148.7	147.1	11.0
12.0	125.8	128.5	130.0	130.5	129.6	128.5	127.0	12.0
14.0		99.8	101.3	101.7	100.9	99.9	98.4	14.0
16.0		80.6	81.9	82.3	81.5	80.5	79.1	16.0
18.0		66.9	68.0	68.4	67.6	66.6	65.3	18.0
20.0			57.6	57.9	57.1	56.1	54.8	20.0
22.0			49.6	49.7	48.9	47.9	46.6	22.0
24.0				43.2	42.4	41.4	40.1	24.0
26.0				38.0	37.1	36.1	34.7	26.0
28.0					32.7	31.6	30.3	28.0
30.0					29.1	27.9	26.5	30.0
32.0						24.8	23.3	32.0
34.0						22.1	20.6	34.0
36.0						19.9	18.2	36.0
38.0							16.1	38.0
40.0							14.4	40.0

--	--	--	--	--	--

Boom Length (m)	14.9	19.5	24.1	28.7	33.3	37.9	42.5	m
合計ブーム長さ	15.4	20.0	24.6	29.2	33.8	38.4	43.0	m
6.0	170.0	170.0						6.0
7.0	170.0	170.0	170.0	170.0				7.0
8.0	170.0	170.0	170.0	170.0	170.0	170.0	157.0	8.0
9.0	170.0	170.0	170.0	170.0	170.0	170.0	157.0	9.0
10.0	170.0	170.0	170.0	170.0	170.0	170.0	157.0	10.0
11.0	170.0	170.0	170.0	170.0	170.0	170.0	157.0	11.0
12.0	170.0	170.0	170.0	170.0	170.0	170.0	157.0	12.0
14.0		150.9	151.8	152.2	151.6	150.9	148.5	14.0
16.0		130.5	131.5	131.8	131.2	130.5	129.5	16.0
18.0		76.4	115.5	115.8	115.2	114.5	113.4	18.0
20.0			102.7	103.0	102.4	101.6	100.5	20.0
22.0			73.0	92.4	91.8	91.0	89.9	22.0
24.0				83.4	82.6	81.6	80.2	24.0
26.0				63.9	73.7	72.6	71.3	26.0
28.0					66.3	65.2	63.8	28.0
30.0					55.0	58.9	57.5	30.0
32.0						53.6	52.1	32.0
34.0						47.0	47.5	34.0
36.0						32.2	43.4	36.0
38.0							39.9	38.0
40.0							29.8	40.0

--	--	--	--	--	--

Boom Length (m)	14.9	19.5	24.1	28.7	33.3	37.9	42.5	m
合計ブーム長さ	27.9	32.5	37.1	41.7	46.3	50.9	55.5	m
6.0	170.0	170.0						6.0
7.0	170.0	170.0	170.0					7.0
8.0	170.0	170.0	170.0	157.0				8.0
9.0	170.0	170.0	170.0	157.0	147.0			9.0
10.0	168.8	170.0	170.0	157.0	147.0	136.0		10.0
11.0	154.1	170.0	170.0	157.0	147.0	136.0	120.8	11.0
12.0	141.7	164.5	170.0	157.0	147.0	136.0	120.8	12.0
14.0	121.7	141.8	149.7	147.3	143.3	136.0	120.8	14.0
16.0	106.4	124.3	129.3	127.8	126.3	124.0	114.6	16.0
18.0	94.3	110.5	113.2	111.8	110.3	110.0	106.4	18.0
20.0	84.5	99.3	100.3	98.8	99.1	97.1	97.5	20.0
22.0	76.4	90.0	89.7	88.2	88.4	88.0	86.8	22.0
24.0	69.5	81.7	80.8	79.3	79.5	79.1	77.9	24.0
26.0	38.8	73.8	72.6	72.8	71.0	70.5	69.0	26.0
28.0		62.5	65.1	65.2	64.1	62.9	61.4	28.0
30.0		43.0	58.7	58.8	57.7	56.5	55.0	30.0
32.0			52.2	53.3	52.2	51.0	49.5	32.0
34.0			40.1	48.5	47.4	46.2	44.7	34.0
36.0				44.5	43.3	42.0	40.5	36.0
38.0				35.5	39.6	38.3	36.9	38.0
40.0					36.4	35.1	33.6	40.0
42.0					31.0	32.2	30.7	42.0
44.0					19.6	29.7	28.1	44.0
46.0						26.3	25.8	46.0
48.0						18.4	23.7	48.0
50.0							21.8	50.0
52.0							16.1	52.0

--	--	--	--	--	--

Boom Length (m)	14.9	19.5	24.1	28.7	33.3	37.9	42.5	m
合計ブーム長さ	15.4	20.0	24.6	29.2	33.8	38.4	43.0	m
3.0	170.0							3.0
3.5	170.0	170.0						3.5
4.0	170.0	170.0	170.0					4.0
4.5	170.0	170.0	170.0					4.5
5.0	170.0	170.0	170.0	170.0				5.0
6.0	170.0	170.0	170.0	170.0	170.0			6.0
7.0	170.0	170.0	170.0	170.0	170.0	170.0		7.0
8.0	170.0	170.0	170.0	170.0	170.0	170.0	157.0	8.0
9.0	170.0	170.0	170.0	170.0	170.0	170.0	157.0	9.0
10.0	170.0	170.0	170.0	170.0	170.0	170.0	157.0	10.0
11.0	167.4	169.1	170.0	170.0	169.9	169.1	157.0	11.0
12.0	152.5	154.3	155.3	155.6	155.0	154.3	153.3	12.0
14.0		122.6	124.0	124.5	123.6	122.6	121.2	14.0
16.0		99.6	101.0	101.4	100.6	99.6	98.2	16.0
18.0		76.4	84.4	84.8	84.0	83.0	81.7	18.0
20.0			72.0	72.3	71.5	70.5	69.2	20.0
22.0			62.4	62.5	61.8	60.8	59.4	22.0
24.0				54.8	54.0	53.0	51.6	24.0
26.0				48.5	47.6	46.6	45.3	26.0
28.0					42.4	41.3	39.9	28.0
30.0					38.0	36.8	35.4	30.0
32.0						33.		

ラフィングジブ

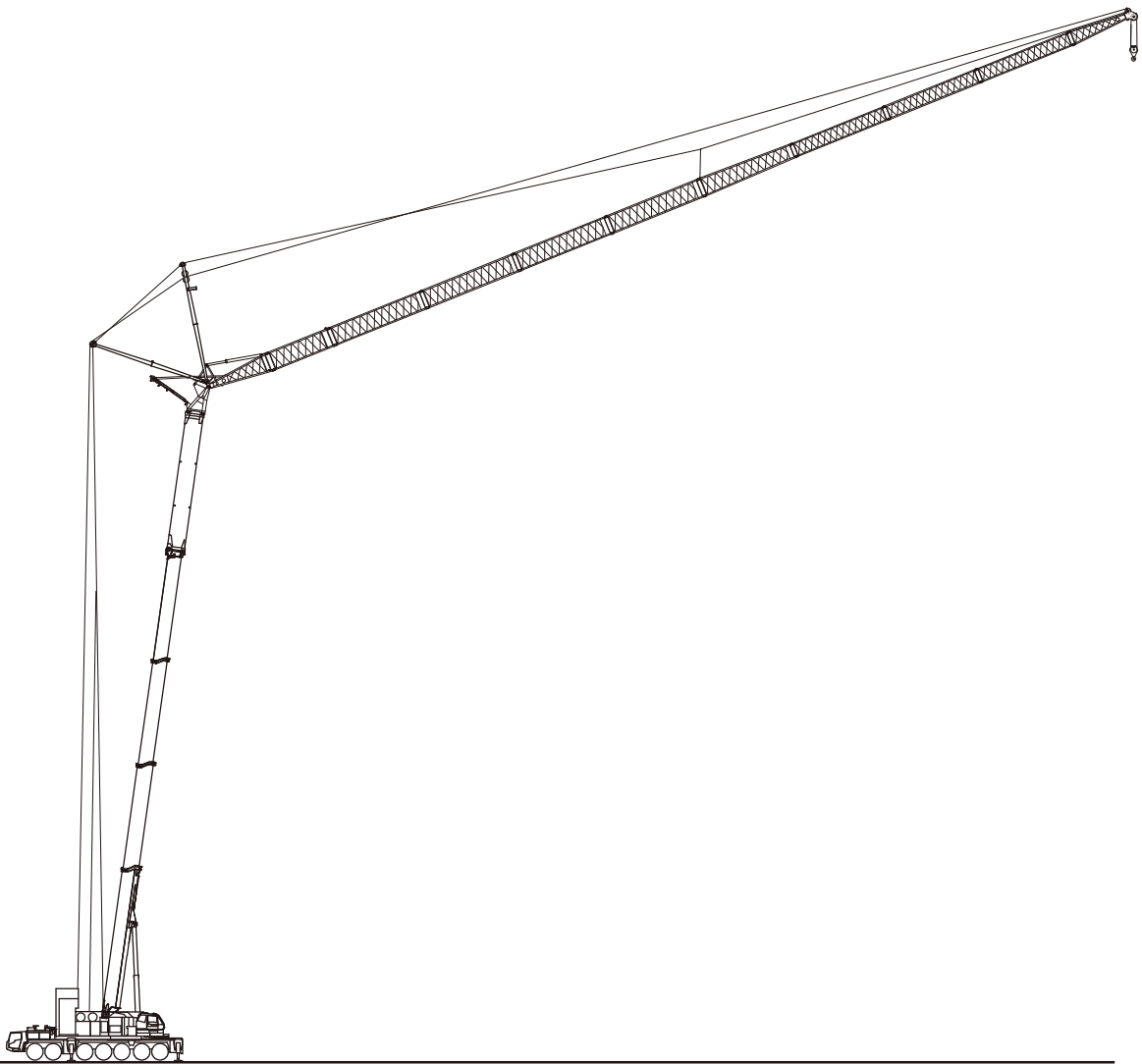

ラフィングジブ



■ ラフィングジブ(LJ)の構成

単位(mm)

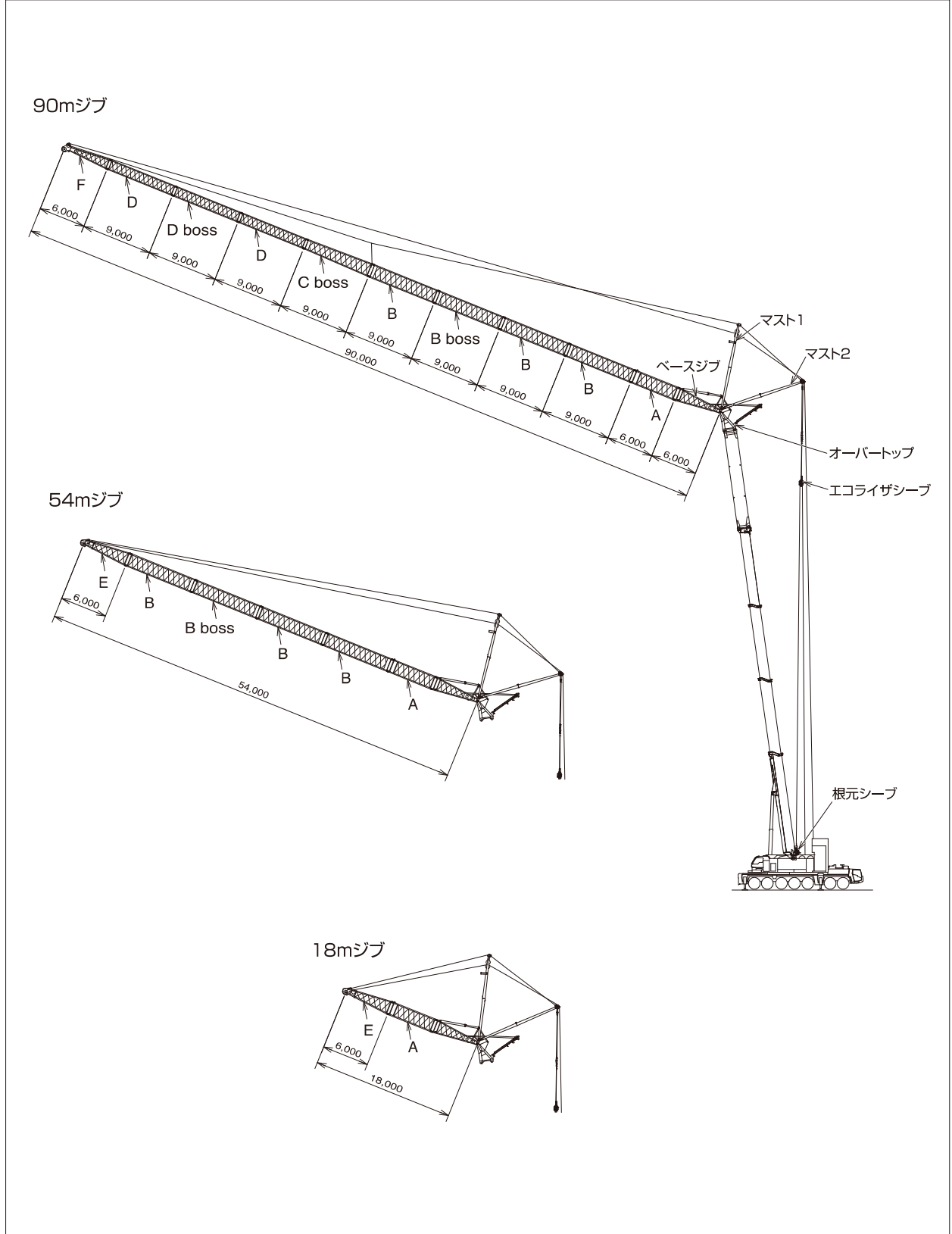

ラフィングジブ



■ ラフィングジブ(LJ)長さ 組合せ

18mジブ	
27mジブ	
36mジブ	
45mジブ	
54mジブ	
63mジブ	
72mジブ	
81mジブ	
90mジブ	

ジブの組合せは上記に従ってください。これ以外の組合せは禁止します。

■ 各部の重量

記号	名称	重量
—	マストAss'y(マスト1+マスト2)	5.3 t
—	ベースジブ+オーバートップ	7.7 t
A	ミドル1ジブ	1.4 t
B	ミドル2ジブ	2.0 t
B boss	ミドル2ジブ+bossジブ	2.0 t
C boss	レデューサジブ	2.1 t
D	ミドル3ジブ	1.6 t
D boss	ミドル3+bossジブ	1.6 t
E	トップ1ジブ	2.6 t
F	トップ2ジブ	1.9 t
—	エコライザシーブ	0.6 t
—	根元シーブ	0.6 t

ラフィングジブ



4段ESPブーム+ラフィングジブ(LJ) 作業半径-揚程図

42.5m4段ESPブーム+2.5m+ラフィングジブ(LJ)

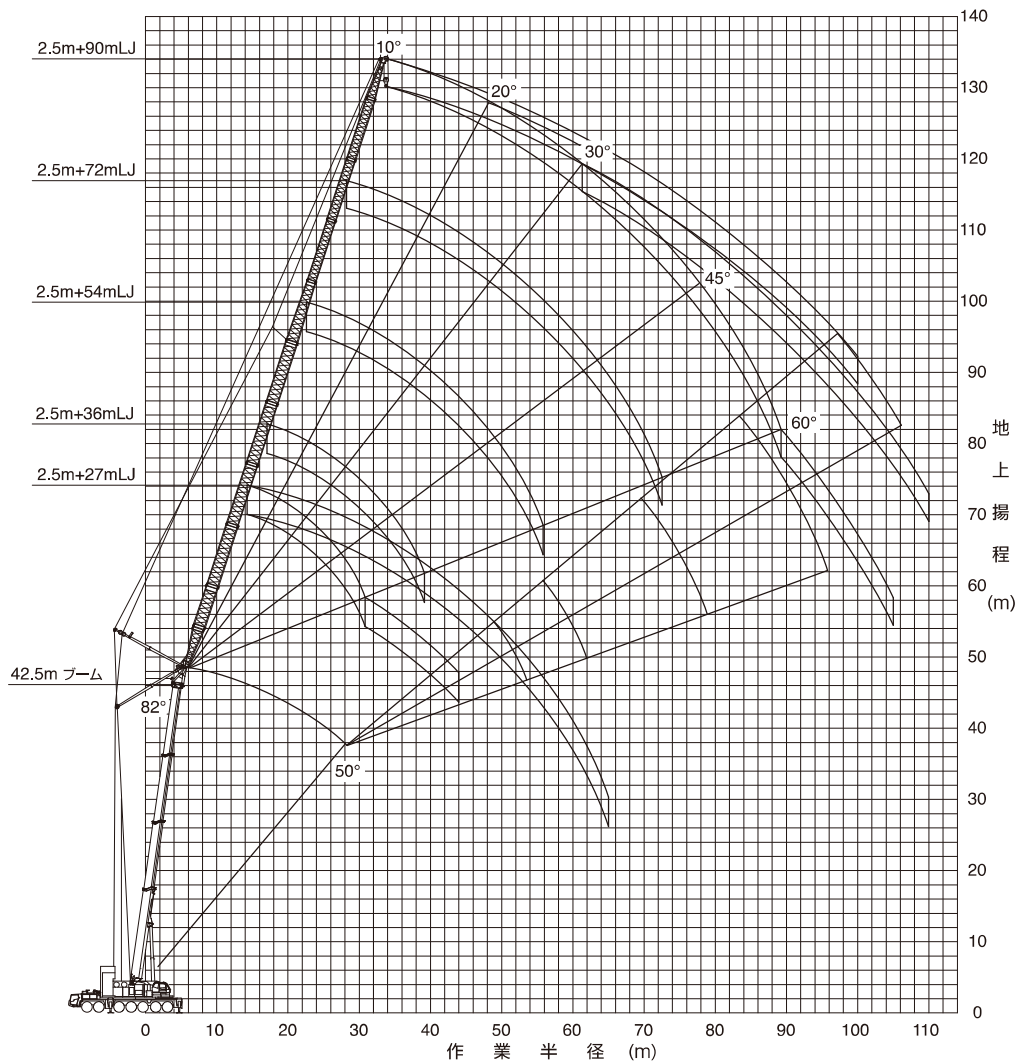

- (注意) 1. 上図はブームおよびジブのたわみを含んでいません。
 2. カウンタウエイト208 t、アウトリガ張出幅9.0m、アシストジャッキ使用時の性能を図示しています。

ラフィングジブ



4段ESPブーム+フィックスブーム(FB)+ラフィングジブ(LJ) 作業半径-揚程図

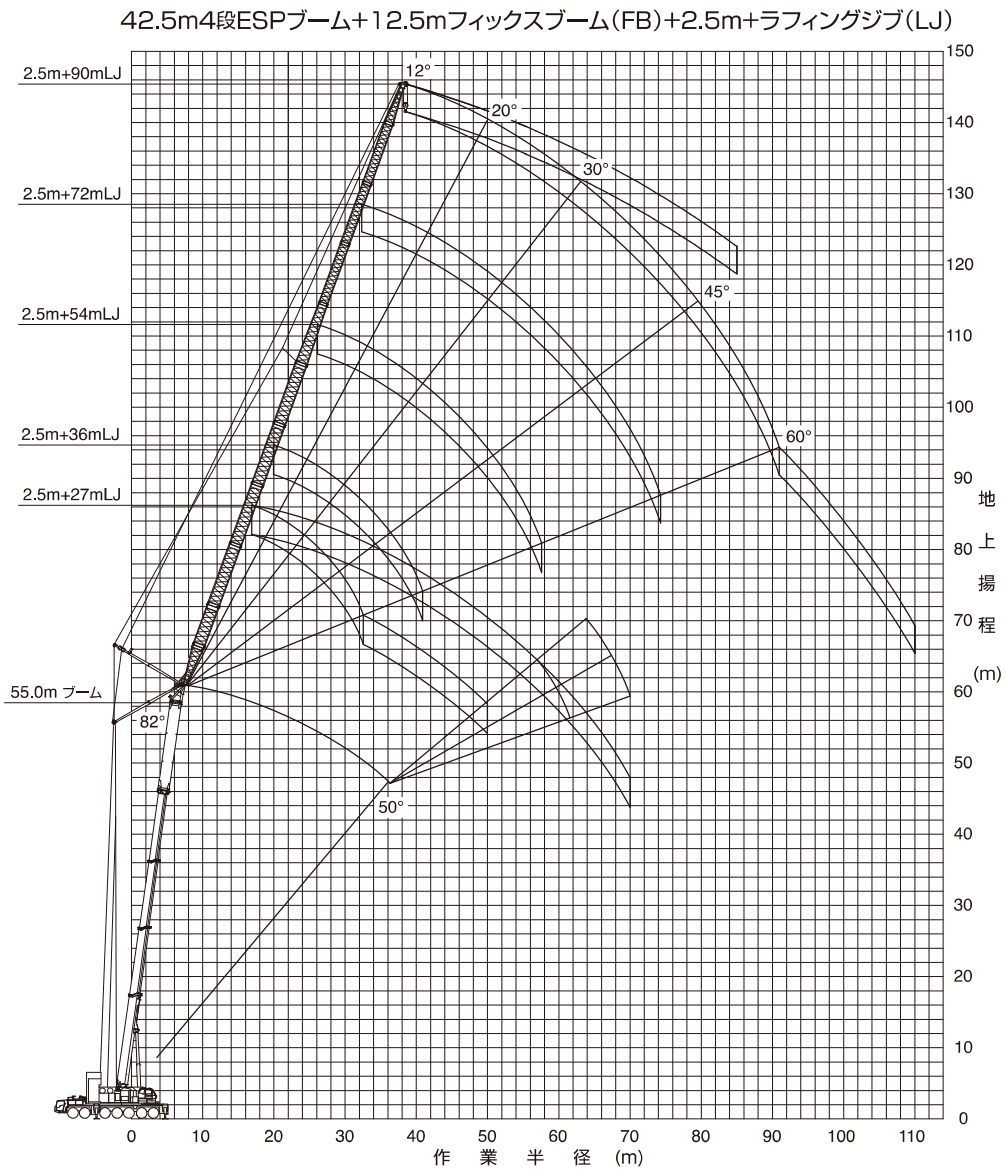

- (注意)
1. 上図はブームおよびジブのたわみを含んでいません。
 2. カウンタウエイト208 t、アウトリガ張出幅9.0m、アシストジャッキ使用時の性能を図示しています。
 3. ブーム長さは、4段ESPブームと12.5mフィックスブームの合計ブーム長さを示しています。

ラフィングジブ



4段ESPブーム+フィックスブーム(FB)×2+ラフィングジブ(LJ) 作業半径-揚程図

33.3m4段ESPブーム+25.0mフィックスブーム(FB)×2+2.5m+ラフィングジブ(LJ)

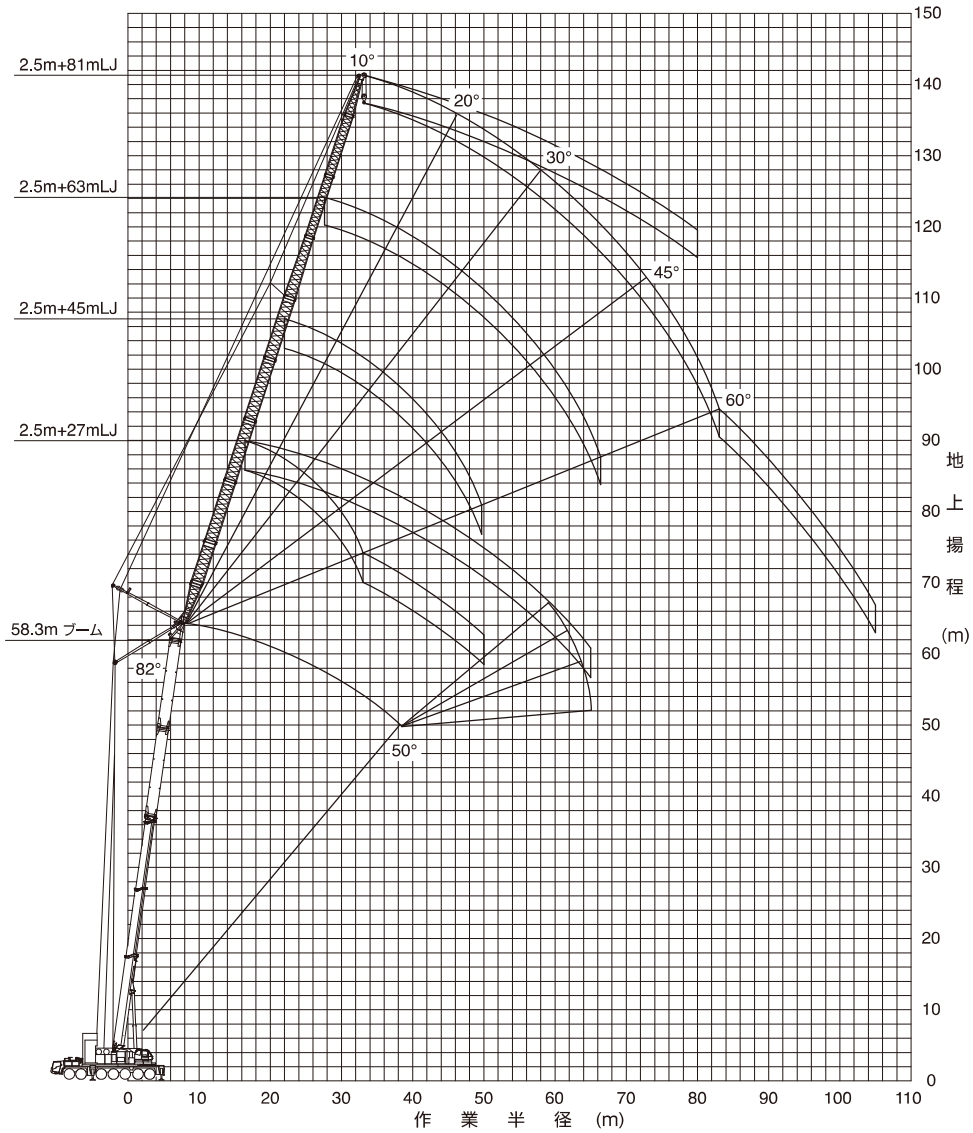

- (注意) 1. 上図はブームおよびジブのたわみを含んでいません。
 2. カウンタウイト208t、アウトリガ張出幅9.0m、アシストジャッキ使用時の性能を图示しています。
 3. ブーム長さは、4段ESPブームと25.0mフィックスブームの合計ブーム長さを示しています。

ラフィングジブ



4段ESPブーム+ラフィングジブ(LJ)、 4段ESPブーム+フィックスブーム(FB)+ラフィングジブ(LJ)、 4段ESPブーム+フィックスブーム(FB)×2+ラフィングジブ(LJ) 定格総荷重表

■ 定格総荷重表注意事項

- ◆性能設定のあるカウンタウエイトとアウトリガ張出幅の組合せを、下表に○印で示します。
AJ付はアシストジャッキを装着している状態を示します。
本仕様書では、**○**の定格総荷重表のみ記載しています。
このため、カウンタウエイトとアウトリガ張出幅の組合せに応じた定格総荷重および他の詳細については、別冊の仕様書を参照してください。

【4段ESPブーム+ラフィングジブ(LJ)】

カウンタウエイト アウトリガ張出幅	208 t	195 t	164 t	127 t	94 t
9.0 m (AJ付)	○ P26	○	○	○	○
9.0 m	○	○	○	○	○
8.0 m	△	△	△	○	△

【4段ESPブーム+フィックスブーム(FB)+ラフィングジブ(LJ)】

カウンタウエイト アウトリガ張出幅	208 t	195 t	164 t	127 t	94 t
9.0 m (AJ付)	○ P29	○	○	○	○
9.0 m	○	○	○	○	○
8.0 m	△	△	△	○	△

【4段ESPブーム+フィックスブーム(FB)×2+ラフィングジブ(LJ)】

カウンタウエイト アウトリガ張出幅	208 t	195 t	164 t	127 t	94 t
9.0 m (AJ付)	○ P32	○	○	△	△
9.0 m	○	○	○	△	△

- ◆定格総荷重は、つり具質量とフック質量(350tフック:3,460kg、150tフック:2,400kg、80tフック:1,870kg、25tフック:1,200kg)を含んだ値を示します。
- ◆定格総荷重は、ブームとジブのたわみを含んだ実際の作業半径に基づいています。
- ◆各状態ごとの標準巻掛本数は別冊の仕様書を参照してください。
- ◆起伏用ワイヤロープは、8本掛けです。
- ◆Bピン(ブーム固定ピン)を挿入していない状態では使用できません。
- ◆定格総荷重は、アウトリガを水平堅土上に設置したときの値です。
- ◆定格総荷重表は、風による影響を含んでいません。瞬間最大風速が10m/s以上の風速では、クレーン作業を中止してください。
- ◆定格総荷重表中の太線より上側はクレーンの強度に基づき、下側はクレーンの安定に基づいています。

定格総荷重表中のシンボル、記号の説明

	4段ESP		2.5m+LJ	4段ESP+ラフィングジブ(LJ)の定格総荷重を示します。		AJ	アシストジャッキ(AJ)を装着している状態を示します。
	4段ESP+12.5mFB		2.5m+LJ	4段ESP+フィックスブーム(FB)+ラフィングジブ(LJ)の定格総荷重を示します。		360°	吊上げ可能な旋回範囲を示します。 360°旋回可能です。
	4段ESP+25.0m2FB		2.5m+LJ	4段ESP+フィックスブーム(FB)×2+ラフィングジブ(LJ)の定格総荷重を示します。		t JPN	定格総荷重の単位を示します。
				ラフィングジブ(LJ)のジブ長さを示します。		m	ブーム長さを示します。
				カウンタウエイト(C/W)組合せを示します。			ジブのオフセット角度を示し、ブームの中心線とジブの中心線のなす角度を示します。
				アウトリガ張出幅を示します。		m	作業半径を示します。

ラフィングジブ

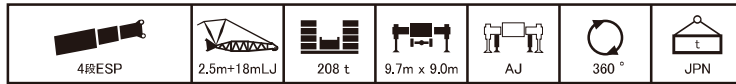

m		24.1	24.1	24.1	24.1	24.1	28.7	28.7	28.7	28.7	28.7	33.3	33.3	33.3	33.3	33.3	m
°		10	20	30	45	60	10	20	30	45	60	10	20	30	45	60	°
12.0	140.0																12.0
14.0	140.0	124.5					136.9	129.7				120.0					14.0
16.0	126.6	114.7	97.7				121.9	120.1	100.6			117.4	117.7				16.0
18.0	113.8	106.2	91.8				109.6	109.8	94.9			105.7	106.1	98.6			18.0
20.0	102.3	99.0	86.7	69.9			99.4	99.7	90.0	72.8		95.8	96.3	93.8			20.0
22.0	91.3	92.8	82.2	67.2	53.8		90.5	91.1	85.6	70.2	56.0	87.5	88.0	88.4	73.6		22.0
24.0	82.0	83.8	78.3	64.8	52.6	81.2	83.1	81.7	67.8	54.8		80.3	80.9	81.4	71.2	57.2	24.0
26.0	74.2	75.7	74.8	62.7	51.6	73.4	75.1	76.6	65.7	53.8	72.9	74.6	75.1	69.1	56.2	26.0	
28.0	66.6	68.1	69.6	60.9	50.9	65.6	67.4	69.0	63.9	53.0	65.1	67.0	68.8	67.2	55.3	28.0	
30.0	59.8	61.1	62.3	59.4		58.8	60.4	61.8	62.2	52.4	58.3	60.0	61.5	63.4	54.6	30.0	
32.0	54.0	55.1	56.1	57.1		53.0	54.4	55.6	56.9		52.5	54.0	55.3	56.9	54.0	32.0	
34.0	48.9	49.9	50.6	51.3		48.0	49.2	50.2	51.2		47.4	48.8	49.9	51.2		34.0	
36.0	44.5	45.2	45.8			43.6	44.6	45.4	46.2		43.0	44.2	45.2	46.3		36.0	
38.0	40.6	41.1	41.5			39.7	40.5	41.2			39.1	40.1	41.0	41.8		38.0	
40.0	35.8	37.5				36.3	36.9	37.4			35.7	36.5	37.2	37.8		40.0	
42.0	24.8					33.2	33.7	34.0			32.6	33.3	33.9			42.0	
44.0						30.2	30.7				29.8	30.4	30.8			44.0	
46.0						22.4					27.3	27.7	28.0			46.0	
48.0											25.0	25.3				48.0	
50.0											19.6					50.0	

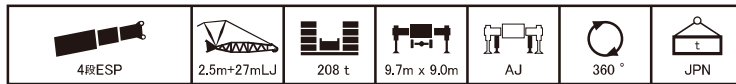

m		24.1	24.1	24.1	24.1	24.1	28.7	28.7	28.7	28.7	28.7	33.3	33.3	33.3	33.3	33.3	37.9	37.9	37.9	37.9	37.9	37.9	42.5	42.5	42.5	42.5	42.5	m
°		10	20	30	45	60	10	20	30	45	60	10	20	30	45	60	10	20	30	45	60	10	20	30	45	60	°	
14.0	118.5						107.2																					14.0
16.0	106.9						107.2					91.5					75.9											16.0
18.0	96.5	83.7					99.9	85.8				91.5					75.9	75.9						63.8				18.0
20.0	87.9	77.6					91.3	79.8				91.5	83.7				75.9	75.9						63.8	63.8			20.0
22.0	80.7	72.3	63.5				83.9	74.6	65.3			86.3	78.4				75.9	75.9						63.8	63.8			22.0
24.0	74.6	67.7	60.1				77.7	70.1	62.0			79.4	73.7	64.8			75.9	75.8	66.3					63.8	63.8			24.0
26.0	69.3	63.7	57.0	47.0			72.3	66.0	59.0			73.3	69.5	61.8			70.7	71.5	63.3					63.8	63.8	63.8		26.0
28.0	64.7	60.1	54.3	45.2			67.5	62.4	56.3	46.8		68.0	65.8	59.0	48.9		65.6	66.4	60.7					63.0	63.8	62.2		28.0
30.0	60.6	56.9	51.9	43.6	35.6		61.9	59.2	53.9	45.3	37.0	61.3	62.5	56.6	47.3		60.9	61.9	58.2	48.6				63.0	63.8	59.8	49.7	30.0
32.0	57.0	54.0	49.7	42.2	34.8		56.0	56.4	51.7	43.9	36.2	55.4	57.7	54.3	45.9	37.8	55.0	57.4	56.0	47.2	38.8			54.6	55.7	56.5	48.3	32.0
34.0	51.9	51.4	47.7	40.9	34.1		50.9	52.8	49.7	42.7	35.5	50.2	52.4	52.3	44.7	37.1	49.9	52.1	53.9	45.9	38.1	49.5	51.8	53.0	47.1	39.0	34.0	
36.0	47.5	49.0	45.9	39.8	33.6		46.4	48.1	47.9	41.5	34.9	45.7	47.7	49.5	43.5	36.5	45.4	47.4	49.3	44.8	37.5	45.0	47.1	49.1	45.9	38.4	36.0	
38.0	43.5	44.9	44.2	38.8			42.4	44.0	45.5	40.5	34.5	41.8	43.5	45.1	42.4	36.0	41.4	43.3	45.0	43.7	36.9	41.1	43.0	44.8	44.9	37.8	38.0	
40.0	40.0	41.2	42.3	39.0			38.9	40.3	41.6	39.6		38.3	39.8	41.3	41.5	35.5	37.9	39.6	41.1	42.8	36.5	37.6	39.3	41.0	43.1	37.3	40.0	
42.0	36.8	37.8	38.8	37.3			35.8	37.0	38.1	38.8		35.1	36.5	37.8	39.4		34.8	36.3	37.7	39.4	36.1	34.4	36.0	37.5	39.4	36.9	42.0	
44.0	34.0	34.8	35.6				32.9	34.0	35.0	36.1		32.3	33.5	34.7	36.0		31.9	33.3	34.6	36.1		31.6	33.1	34.4	36.1	36.6	44.0	
46.0	31.4	32.1	32.7				30.4	31.3	32.1	33.0		29.7	30.8	31.8	32.9		29.4	30.6	31.8	33.1		29.1	30.4	31.6	33.1		46.0	
48.0	29.1	29.6					28.1	28.8	29.5			27.4	28.3	29.2	30.1		27.0	28.2	29.2	30.3		27.0	28.0	29.1	30.4		48.0	
50.0	23.4						25.9	26.6	27.1			25.2	26.1	26.8			24.9	25.9	26.8	27.7		24.6	25.7	26.7	27.9		50.0	
55.0							16.8					20.6	21.2	21.5			20.3	21.1	21.7			20.1	20.9	21.6			55.0	
60.0																	16.6	17.0				16.3	16.9	17.4			60.0	
65.0																						13.1	13.5				65.0	

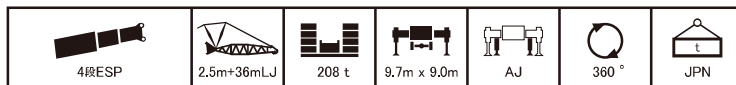

m		24.1	24.1	24.1	24.1	24.1	28.7	28.7	28.7	28.7	28.7	33.3	33.3	33.3	33.3	33.3	37.9	37.9	37.9	37.9	37.9	37.9	42.5	42.5	42.5	42.5	42.5	m	
°		10	20	30	45	60	10	20	30	45	60	10	20	30	45	60	10	20	30	45	60	10	20	30	45	60	°		
16.0	84.8																											16.0	
18.0	82.7						73.1					63.7																18.0	
20.0	75.1						73.1					63.7					54.0							46.2				20.0	
22.0	68.8	61.6					72.8	64.5				63.7					54.0							46.2				22.0	
24.0	63.4	57.5					67.0	60.3				63.7	61.5				54.0	54.0						46.2				24.0	
26.0	58.7	53.9					62.1	56.6				63.7	57.8				54.0	54.0						46.2	46.2			26.0	
28.0	54.7	50.7	45.6				57.8	53.3	47.7			59.7	54.6				54.0	54.0						46.2	46.2			28.0	
30.0	51.1	47.9	43.3				54.0	50.3	45.5			55.8	51.7	46.5			54.0	53.0	47.5					46.2	46.2			30.0	
32.0	48.0	45.3	41.3				50.7	47.7	43.4			52.4	49.0	44.5			54.0	50.3	45.5					46.2	46.2	46.2		32.0	
34.0	45.2	43.0	39.5	33.2			47.7	45.3	41.6	34.9		49.4	46.7	42.7			51.2	48.0	43.7					46.2	46.2	44.7		34.0	
36.0	42.7	40.9	37.8	32.1			45.1	43.2	39.8	33.8		46.7	44.5	41.0	34.7		47.3	45.8	42.0	35.5				46.2	46.2	43.0		36.0	
38.0	40.4	39.0	36.3	31.0	25.4		42.7	41.2	38.3	32.7		43.8	42.5	39.4	33.7		43.3	43.8	40.5	34.5				42.8	45.1	41.5	35.3	38.0	
40.0	38.3	37.3	34.9	30.1	24.8		40.5	39.4	36.8	31.7	26.2	40.2	40.7	38.0	32.7	27.0	39.7	42.0	39.1	33.6				39.3	41.6	40.1	34.4	40.0	
42.0	36.5	35.7	33.6	29.2	24.3		38.0	37.7	35.5	30.9	25.7	37.0	39.0	36.7	31.9	26.5	36.5	38.6	37.8	32.7	27.3			36.1	38.2	38.8	33.5	27.9	42.0
44.0	34.8	34.3	32.4	28.4	23.9		35.1	36.2	34.3	30.1	25.2	34.1	35.9	35.5	31.1	26.1	33.7	35.6	36.5	31.9	26.8			33.2	35.2	37.2	32.8	27.5	44.0
46.0	33.2	32.9	31.4	27.7	23.6		32.4	33.9	33.2	29.3	24.8	31.0	33.2	34.3	30.3	25.7	31.0	32.8	34.5	31.2	26.4			30.6	32.5	34.3	32.0	27.1	46.0
48.0	30.9	31.7	30.4	27.1			30.1	31.4	32.1	28.7	24.6	29.1																	

ラフィングジブ

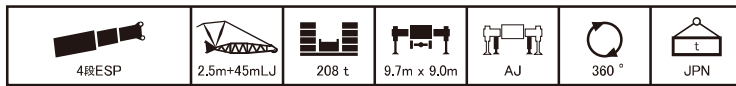

m		24.1	24.1	24.1	24.1	24.1	28.7	28.7	28.7	28.7	28.7	33.3	33.3	33.3	33.3	33.3	37.9	37.9	37.9	37.9	37.9	42.5	42.5	42.5	42.5	42.5	m	
°		10	20	30	45	60	10	20	30	45	60	10	20	30	45	60	10	20	30	45	60	10	20	30	45	60	°	
20.0	59.2						50.0																				20.0	
22.0	59.2						50.0					45.9						39.5									22.0	
24.0	57.4						50.0					45.9						39.5					34.1				24.0	
26.0	53.0	48.4					50.0					45.9						39.5					34.1				26.0	
28.0	49.2	45.4					50.0	48.2				45.9	45.9					39.5					34.1				28.0	
30.0	45.9	42.7					49.0	45.4				45.9	45.9					39.5	39.5				34.1	34.1			30.0	
32.0	42.9	40.3	36.5				45.8	42.8				45.9	43.7					39.5	39.5				34.1	34.1			32.0	
34.0	40.3	38.1	34.7				42.9	40.5	36.8			44.1	41.4	37.5				39.5	39.5				34.1	34.1			34.0	
36.0	38.0	36.2	33.1				40.4	38.4	35.1			41.5	39.3	35.9				39.5	39.5	36.5			34.1	34.1	34.1		36.0	
38.0	35.8	34.4	31.7				38.1	36.5	33.6			39.2	37.4	34.4				39.5	38.3	35.1			34.1	34.1	34.1		38.0	
40.0	33.9	32.8	30.3	25.6			36.0	34.8	32.2			37.1	35.7	33.0				38.3	36.6	33.7			34.1	34.1	34.1		40.0	
42.0	32.2	31.3	29.1	24.7			34.2	33.2	30.9	26.2		35.2	34.1	31.7	26.9			36.3	35.0	32.5			34.1	34.1	33.2		42.0	
44.0	30.6	29.9	28.0	23.9			32.5	31.8	29.7	25.4		33.5	32.7	30.6	26.1			34.5	33.6	31.3	26.7		34.1	34.1	32.0		44.0	
46.0	29.1	28.6	26.9	23.1	18.8		30.9	30.4	28.6	24.6		31.9	31.3	29.5	25.4			32.4	32.2	30.2	26.0		31.9	33.1	31.0	26.6	46.0	
48.0	27.8	27.5	25.9	22.4	18.4		29.5	29.2	27.6	23.9	19.6	30.4	30.1	28.5	24.7	20.2		30.0	31.0	29.2	25.3		29.5	31.7	30.0	25.9	48.0	
50.0	26.5	26.4	25.0	21.8	18.0		28.1	28.0	26.7	23.2	19.2	28.3	28.9	27.5	24.0	19.8		27.8	29.8	28.3	24.7	20.4	27.3	29.4	29.0	25.3	20.9	50.0
55.0	23.8	24.0	23.0	20.4	17.2		24.5	25.5	24.6	21.8	18.3	23.5	25.1	25.4	22.6	19.0		23.1	24.7	26.2	23.2	19.6	22.6	24.3	26.0	23.9	20.1	55.0
60.0	21.3	22.0	21.4	19.4			20.6	21.6	22.7	20.7		19.6	20.9	22.1	21.4			19.2	20.5	21.8	22.0	19.0	18.7	20.2	21.6	22.7	19.4	60.0
65.0	18.1	18.6	19.1				17.3	18.1	18.8			16.3	17.3	18.3	19.3			15.9	17.0	18.1	19.4		15.4	16.7	17.8	19.3	65.0	
70.0							14.4	14.9				13.6	14.3	14.9				13.1	14.0	14.8			12.6	13.7	14.6	15.7	70.0	
75.0												10.9	11.4					10.5	11.2	11.8			10.0	10.9	11.7		75.0	
80.0																		8.0	8.5				7.7	8.4	8.9		80.0	
85.0																							5.5				85.0	

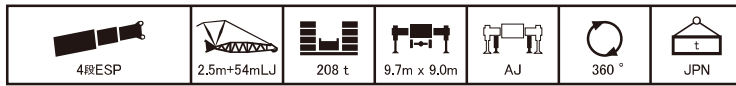

m		24.1	24.1	24.1	24.1	24.1	28.7	28.7	28.7	28.7	28.7	33.3	33.3	33.3	33.3	33.3	37.9	37.9	37.9	37.9	37.9	42.5	42.5	42.5	42.5	42.5	m	
°		10	20	30	45	60	10	20	30	45	60	10	20	30	45	60	10	20	30	45	60	10	20	30	45	60	°	
22.0	43.3						38.5																				22.0	
24.0	43.3						38.5					34.5						30.0									24.0	
26.0	43.3						38.5					34.5						30.0					26.2				26.0	
28.0	43.3						38.5					34.5						30.0					26.2				28.0	
30.0	43.3	39.9					38.5					34.5						30.0					26.2				30.0	
32.0	40.3	37.5					38.5	38.0				34.5	34.5					30.0					26.2				32.0	
34.0	37.7	35.4					38.3	35.9				34.5	34.5					30.0	30.0				26.2	26.2			34.0	
36.0	35.4	33.4					36.0	34.0				34.5	34.5					30.0	30.0				26.2	26.2			36.0	
38.0	33.3	31.7	28.8				33.9	32.2				34.5	32.8					30.0	30.0				26.2	26.2			38.0	
40.0	31.4	30.1	27.5				32.0	30.7	28.1			32.7	31.2	28.6				30.0	30.0				26.2	26.2			40.0	
42.0	29.7	28.6	26.3				30.3	29.2	26.9			31.0	29.8	27.4				30.0	30.0	27.9			26.2	26.2	26.2		42.0	
44.0	28.1	27.2	25.2				28.7	27.9	25.8			29.4	28.5	26.4				30.0	29.1	26.9			26.2	26.2	26.2		44.0	
46.0	26.7	26.0	24.1				27.2	26.6	24.8			27.9	27.2	25.3				28.7	27.8	25.9			26.2	26.2	26.2		46.0	
48.0	25.3	24.8	23.1	19.5			25.9	25.5	23.8			26.6	26.1	24.4				27.3	26.7	24.9			26.2	26.2	25.4		48.0	
50.0	24.1	23.7	22.2	18.8			24.7	24.4	22.9	19.5		25.3	25.0	23.5	20.1			26.1	25.6	24.1			26.2	26.2	24.6		50.0	
55.0	21.5	21.4	20.2	17.4	13.9		22.0	22.0	20.9	18.1	14.5	22.6	22.6	21.5	18.6			23.3	23.3	22.1	19.2		23.1	23.9	22.6	19.6	55.0	
60.0	19.2	19.4	18.5	16.1	13.1		19.8	20.0	19.2	16.8	13.8	20.3	20.6	19.9	17.4	14.3		19.7	21.2	20.4	18.0	14.8	19.2	21.0	21.0	18.4	15.2	60.0
65.0	17.4	17.7	17.1	15.1			17.9	18.3	17.8	15.8	13.2	17.0	18.3	18.4	16.4	13.7		16.4	17.9	19.0	16.9	14.1	15.9	17.5	19.0	17.4	14.6	65.0
70.0	15.7	16.3	15.9	14.4			15.1	16.0	16.6	15.0		14.2	15.3	16.4	15.6			13.6	14.9	16.1	16.1	13.7	13.1	14.5	15.8	16.5	14.1	70.0
75.0	13.4	14.1					12.7	13.4	14.0			11.7	12.6	13.5	14.5			11.1	12.2	13.3	14.5		10.5	11.8	13.0	14.4	75.0	
80.0							9.8	10.8				9.4	10.1	10.7				8.8	9.7	10.6			8.2	9.3	10.3	11.5	80.0	
85.0												6.6						6.8	7.4	8.0			6.3	7.1	7.8		85.0	
90.0																							5.1				90.0	

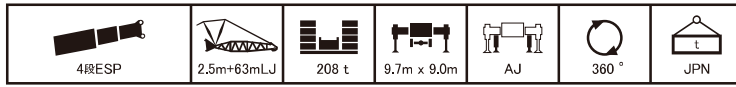

m		24.1	24.1	24.1	24.1	24.1	28.7	28.7	28.7	28.7	28.7	33.3	33.3	33.3	33.3	33.3	37.9	37.9	37.9	37.9	37.9	42.5	42.5	42.5	42.5	42.5	m
°		10	20	30	45	60	10	20	30	45	60	10	20	30	45	60	10	20	30	45	60	10	20	30	45	60	°
26.0	25.0						25.0					25.0															26.0
28.0	25.0						25.0					25.0						22.8									28.0
30.0	25.0						25.0					25.0						22.8					20.0				30.0
32.0	25.0						25.0					25.0						22.8					20.0				32.0
34.0	25.0	25.0					25.0					25.0						22.8					20.0				34.0
36.0	25.0	25.0					25.0	25.0				25.0	25.0					22.8					20.0				36.0
38.0	25.0	25.0					25.0	25.0				25.0	25.0					22.8	22.8				20.0				38.0
40.0	25.0	25.0					25.0	25.0				25.0	25.0					22.8	22.8				20.0	20.0			40.0
42.0	25.0	25.0					25.0	25.0				25.0	25.0					22.8	22.8				20.0	20.0			42.0
44.0	25.0	25.0	25.0				25.0	25.0	25.0			25.0	25.0					22.8	22.8				20.0	20.0			44.0
46.0	25.0	25.0	24.0				25.0	25.0	24.6			25.0	25.0</														

ラフィングジブ

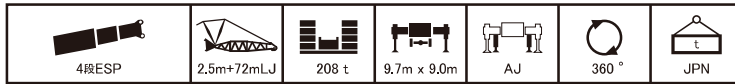

m		24.1	24.1	24.1	24.1	24.1	28.7	28.7	28.7	28.7	28.7	33.3	33.3	33.3	33.3	33.3	37.9	37.9	37.9	37.9	37.9	42.5	42.5	42.5	42.5	42.5	m	
°		10	20	30	45	60	10	20	30	45	60	10	20	30	45	60	10	20	30	45	60	10	20	30	45	60	°	
m	28.0	24.0					21.8																					28.0
	30.0	24.0					21.8					19.8						17.5										30.0
	32.0	24.0					21.8					19.8						17.5					14.9					32.0
	34.0	24.0					21.8					19.8						17.5					14.9					34.0
	36.0	23.5					21.8					19.8						17.5					14.9					36.0
	38.0	22.6					21.8					19.8						17.5					14.9					38.0
	40.0	21.8	20.2				21.8	20.5				19.8						17.5					14.9					40.0
	42.0	21.1	19.6				21.6	19.9				19.8	19.8					17.5	17.5				14.9					42.0
	44.0	20.4	19.0				20.9	19.3				19.8	19.6					17.5	17.5				14.9	14.9				44.0
	46.0	19.7	18.4				20.3	18.8				19.8	19.1					17.5	17.5				14.9	14.9				46.0
	48.0	19.1	17.9				19.6	18.2				19.8	18.6					17.5	17.5				14.9	14.9				48.0
	50.0	18.5	17.4	16.4			19.1	17.7	16.5			19.6	18.1					17.5	17.5				14.9	14.9				50.0
	55.0	17.2	16.2	15.4			17.7	16.6	15.6			18.2	16.9	15.8				17.5	17.3	16.0			14.9	14.9	14.9			55.0
	60.0	16.0	15.2	14.5			16.5	15.6	14.7			17.1	15.9	14.9				17.5	16.3	15.2			14.9	14.9	14.9			60.0
	65.0	15.0	14.3	13.7	12.1		15.5	14.7	14.0	12.6		16.0	15.1	14.2	13.0			16.5	15.4	14.4	13.3		14.9	14.9	14.7			65.0
	70.0	14.0	13.6	13.1	11.1		14.3	13.9	13.3	11.6		14.7	14.3	13.6	12.1			15.1	14.6	13.8	12.4		14.9	14.9	14.0	12.8		70.0
	75.0	12.6	12.8	12.1	10.2	7.8	12.9	13.2	12.6	10.8	8.3	13.3	13.6	13.0	11.2	8.7	13.1	13.9	13.2	11.6	9.1	12.6	14.3	13.5	12.0	9.4		75.0
	80.0	11.4	11.6	11.1	9.5	7.3	11.7	12.1	11.6	10.0	7.8	11.5	12.5	12.1	10.5	8.2	11.0	12.4	12.5	10.9	8.6	10.4	11.9	12.9	11.2	8.9		80.0
	85.0	10.3	10.7	10.3	8.9		10.5	11.1	10.8	9.4		9.6	10.7	11.2	9.9	7.9	9.0	10.3	11.5	10.2	8.2	8.4	9.9	11.2	10.6	8.5		85.0
	90.0	9.4	9.8	9.6			8.7	9.6	10.0	8.9		7.8	8.8	9.8	9.3		7.2	8.3	9.5	9.7		6.6	7.9	9.1	10.0	8.2		90.0
95.0	5.9					7.1	7.7	8.2			6.1	6.9	7.7			5.5	6.5	7.4	8.6		4.9	6.0	7.1	8.5			95.0	
100.0						3.1					4.6	5.2				4.1	4.8	5.5			3.5	4.4	5.3				100.0	
105.0																								3.5				105.0

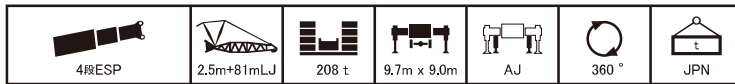

m		24.1	24.1	24.1	24.1	24.1	28.7	28.7	28.7	28.7	28.7	33.3	33.3	33.3	33.3	33.3	37.9	37.9	37.9	37.9	37.9	42.5	42.5	42.5	42.5	42.5	m	
°		10	20	30	45	60	10	20	30	45	60	10	20	30	45	60	10	20	30	45	60	10	20	30	45	60	°	
m	30.0	17.6					16.1					14.7																30.0
	32.0	17.6					16.1					14.7						13.1					11.1					32.0
	34.0	17.6					16.1					14.7						13.1					11.1					34.0
	36.0	17.6					16.1					14.7						13.1					11.1					36.0
	38.0	17.6					16.1					14.7						13.1					11.1					38.0
	40.0	17.6					16.1					14.7						13.1					11.1					40.0
	42.0	17.6					16.1					14.7						13.1					11.1					42.0
	44.0	17.6	17.6				16.1	16.1				14.7						13.1					11.1					44.0
	46.0	17.6	17.6				16.1	16.1				14.7	14.7					13.1	13.1				11.1					46.0
	48.0	17.6	17.6				16.1	16.1				14.7	14.7					13.1	13.1				11.1	11.1				48.0
	50.0	17.6	17.6				16.1	16.1				14.7	14.7					13.1	13.1				11.1	11.1				50.0
	55.0	17.6	17.5	15.9			16.1	16.1				14.7	14.7					13.1	13.1				11.1	11.1				55.0
	60.0	15.9	15.5	14.2			16.1	15.8	14.6			14.7	14.7	14.7				13.1	13.1	13.1			11.1	11.1	11.1			60.0
	65.0	14.0	13.8	12.7			14.3	14.1	13.1			14.6	14.5	13.5				13.1	13.1	13.1			11.1	11.1	11.1			65.0
	70.0	12.5	12.4	11.5	9.3		12.7	12.7	11.9	9.7		13.0	13.0	12.2				13.1	13.1	12.5			11.1	11.1	11.1			70.0
	75.0	11.1	11.1	10.4	8.4		11.3	11.5	10.8	8.9		11.6	11.8	11.1	9.3			11.9	12.1	11.5	9.6		11.1	11.1	11.1	9.8		75.0
	80.0	9.9	10.0	9.4	7.7	5.5	10.1	10.3	9.8	8.1	5.9	10.4	10.7	10.2	8.5			10.7	11.0	10.5	8.8		10.4	11.1	10.8	9.1		80.0
	85.0	8.9	9.0	8.5	7.0	5.0	9.1	9.4	9.0	7.5	5.4	9.3	9.7	9.3	7.9	5.8		9.0	10.0	9.7	8.2	6.1	8.4	10.1	10.0	8.5	6.4	85.0
	90.0	7.9	8.2	7.8	6.4	4.6	8.1	8.5	8.2	6.9	5.1	7.8	8.8	8.6	7.3	5.4		7.2	8.6	8.9	7.6	5.7	6.5	8.1	9.2	7.9	6.0	90.0
	95.0	7.1	7.4	7.1	6.0		7.2	7.7	7.5	6.4		6.2	7.3	7.9	6.8	5.1		5.5	6.8	8.1	7.1	5.4	4.9	6.3	7.7	7.4	5.7	95.0
100.0	6.4	6.7	6.6			5.7	6.4	7.0			4.7	5.7	6.6	6.4			4.1	5.2	6.2	6.7		3.5	4.7	5.9	7.0		100.0	
105.0						4.3	4.9	5.3			3.4	4.1	4.8									3.7	4.5	5.6			105.0	

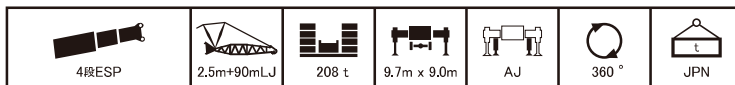

m		24.1	24.1	24.1	24.1	24.1	28.7	28.7	28.7	28.7	28.7	33.3	33.3	33.3	33.3	33.3	37.9	37.9	37.9	37.9	37.9	42.5	42.5	42.5	42.5	42.5	m	
°		10	20	30	45	60	10	20	30	45	60	10	20	30	45	60	10	20	30	45	60	10	20	30	45	60	°	
m	34.0	10.3					9.4					8.6																34.0
	36.0	10.3					9.4					8.6						7.6										36.0
	38.0	10.3					9.4					8.6						7.6					6.8					38.0
	40.0	10.3					9.4					8.6						7.6					6.8					40.0
	42.0	10.3					9.4					8.6						7.6					6.8					42.0
	44.0	10.3					9.4					8.6						7.6					6.8					44.0
	46.0	10.3					9.4					8.6						7.6					6.8					46.0
	48.0	10.0	9.1				9.4	9.3				8.6						7.6					6.8					48.0
	50.0	9.6	8.8				9.4	8.9				8.6	8.6					7.6	7.6				6.8					50.0
	55.0	8.6	7.9				9.0	8.1				8.6	8.3					7.6	7.6				6.8	6.8				55.0
	60.0	7.8	7.2	6.6			8.1	7.4				8.4	7.6					7.6	7.6				6.8	6.8				60.0
	65.0	7.1	6.6	6.1			7.4	6.8	6.2			7.7	7.0	6.3				7.6	7.1	6.4			6.8	6.8	6.5			65.0
	70.0	6.5	6.0	5.6			6.7	6.2	5.7			7.0	6.4	5.8				7.3	6.6	5.9			6.8	6.8	6.1			70.0
	75.0	5.9	5.5	5.2			6.2	5.7	5.3			6.4	5.9	5.4				6.7	6.1	5.5			6.8	6.3	5.7			

ラフィングジブ



4段ESP+12.5mFB	2.5m+27mLJ	208 t	9.7m x 9.0m	AJ	360°	JPN
---------------	------------	-------	-------------	----	------	-----

m		24.1	24.1	24.1	24.1	24.1	28.7	28.7	28.7	28.7	28.7	33.3	33.3	33.3	33.3	33.3	37.9	37.9	37.9	37.9	37.9	42.5	42.5	42.5	42.5	42.5	m					
合計ブーム長さm		36.6	36.6	36.6	36.6	36.6	41.2	41.2	41.2	41.2	41.2	45.8	45.8	45.8	45.8	45.8	50.4	50.4	50.4	50.4	50.4	55.0	55.0	55.0	55.0	55.0	m					
°		10	20	30	45	60	10	20	30	45	60	10	20	30	45	60	10	20	30	45	60	12	20	30	45	60	°					
16.0	96.5																										16.0					
18.0	96.3						82.8									71.1												18.0				
20.0	95.5	83.3					82.6									71.1						59.6						20.0				
22.0	89.6	78.3					81.6	79.7								71.1	71.1					59.1				50.7		22.0				
24.0	81.8	73.8	64.5				80.0	75.4								71.1	71.1					58.5	59.8			50.2		24.0				
26.0	74.1	69.9	61.7				73.0	71.5	62.8							69.7	71.0	65.6				57.9	59.1			49.6	50.5	26.0				
28.0	67.3	66.3	59.1				66.2	68.0	60.3							65.5	67.7	63.1				57.3	58.3	59.9		49.0	49.7	28.0				
30.0	61.2	63.1	56.8	47.3			59.8	62.9	58.0	48.1						59.1	62.3	60.8				55.8	56.5	57.5		47.8	48.1	48.7	30.0			
32.0	55.2	57.7	54.7	46.0	37.7		53.8	56.6	55.9	46.9						53.1	56.1	58.6	48.7			52.4	54.1	54.9	49.4		45.9	46.2	46.7	32.0		
34.0	49.9	52.3	52.7	44.8	37.1		48.6	51.2	53.6	45.7	37.8					47.9	50.6	53.2	47.5	39.0		47.2	50.1	52.4	48.2		44.0	44.3	44.7	45.0	34.0	
36.0	45.4	47.5	49.5	43.7	36.5	44.1	46.4	48.6	44.6	37.2						43.3	45.8	48.2	46.4	38.5		42.7	45.3	47.7	47.2	39.0	42.2	42.4	42.7	43.0	36.0	
38.0	41.3	43.3	45.1	42.7	36.0	40.1	42.2	44.2	43.7	36.7						39.3	41.6	43.7	45.4	38.0		38.7	41.1	43.3	46.2	38.5	38.6	40.6	40.9	41.0	39.8	38.0
40.0	37.8	39.5	41.2	41.8	35.6	36.5	38.4	40.3	42.6	36.3	35.7	37.8	39.8	42.3	37.5	35.1	37.3	39.4	42.0	38.1		35.1	37.3	39.4	42.0	38.1	35.0	36.8	39.0	39.2	38.7	40.0
42.0	34.6	36.2	37.6	39.5	35.3	33.3	35.1	36.7	38.8	35.9	32.5	34.5	36.3	38.5	37.2	31.9	34.0	35.9	38.3	37.7		31.9	34.0	35.9	38.3	37.7	31.8	33.5	35.5	37.5	37.1	42.0
44.0	31.7	33.1	34.5	36.1			30.4	32.0	33.5	35.4	35.7					29.6	31.4	33.1	35.1	36.4		29.0	30.9	32.7	34.9	36.3	28.9	30.5	32.3	34.6	35.5	44.0
46.0	29.1	30.4	31.6	32.9			27.8	29.3	30.7	32.3						27.0	28.7	30.2	32.0	33.1		26.4	28.2	29.8	31.8	33.0	26.3	27.7	29.4	31.5	33.0	46.0
48.0	26.7	27.9	28.9	30.1			25.4	26.8	28.0	29.4						24.6	26.2	27.5	29.2			24.1	25.7	27.2	29.0	30.0	23.9	25.2	26.8	28.7	30.0	48.0
50.0	24.5	25.6	26.5	27.4			23.3	24.5	25.6	26.8						22.5	23.9	25.1	26.5			21.9	23.4	24.8	26.4		21.7	23.0	24.4	26.2	27.2	50.0
55.0	19.9	20.6	21.2				18.6	19.6	20.4							17.8	18.9	19.8	20.8			17.2	18.5	19.5	20.7		17.0	18.0	19.2	20.6		55.0
60.0	15.8	16.4					14.8	15.5	16.0							14.0	14.8	15.5				13.4	14.4	15.2	16.0		13.1	14.0	14.9	15.9		60.0
65.0							10.7	11.9								10.5	11.1	11.5				9.9	10.7	11.3			9.5	10.3	11.1		65.0	
70.0																6.5						6.9	7.5				6.5	7.1	7.7		70.0	

4段ESP+12.5mFB	2.5m+36mLJ	208 t	9.7m x 9.0m	AJ	360°	JPN
---------------	------------	-------	-------------	----	------	-----

m		24.1	24.1	24.1	24.1	24.1	28.7	28.7	28.7	28.7	28.7	33.3	33.3	33.3	33.3	33.3	37.9	37.9	37.9	37.9	37.9	42.5	42.5	42.5	42.5	42.5	m										
合計ブーム長さm		36.6	36.6	36.6	36.6	36.6	41.2	41.2	41.2	41.2	41.2	45.8	45.8	45.8	45.8	45.8	50.4	50.4	50.4	50.4	50.4	55.0	55.0	55.0	55.0	55.0	m										
°		10	20	30	45	60	10	20	30	45	60	10	20	30	45	60	10	20	30	45	60	12	20	30	45	60	°										
18.0	67.5																											18.0									
20.0	67.5						59.5																					20.0									
22.0	67.5						59.5										52.3										45.0		22.0								
24.0	67.5	61.1					59.5										52.3										45.0		24.0								
26.0	64.6	57.7					59.5	58.5									52.3											38.6		26.0							
28.0	60.3	54.6					59.5	55.5									52.3	52.3									45.0	45.0		28.0							
30.0	56.6	51.8	46.4				58.3	52.8									52.3	52.3									45.0	45.0		38.6	38.6	30.0					
32.0	53.3	49.3	44.5				54.9	50.3	45.2								52.3	51.3	45.7								44.8	45.0		38.6	38.6	32.0					
34.0	50.3	47.0	42.7				50.9	48.1	43.5								49.7	49.1	44.1								44.5	45.0	45.0		38.2	38.6	34.0				
36.0	47.6	44.9	41.1	34.7			46.3	46.0	41.9								45.0	47.0	42.6								44.1	45.0	45.0		37.6	38.1	38.6	36.0			
38.0	43.5	43.0	39.7	33.7			42.2	44.1	40.5	34.3							41.0	44.0	41.2	34.7							40.7	43.4	43.6		36.3	36.8	37.5	38.0			
40.0	39.8	41.3	38.3	32.8	27.0		38.5	41.1	39.1	33.4							37.4	40.2	39.9	33.9							37.1	40.0	42.2	35.6		35.0	35.5	36.1	40.0		
42.0	36.6	38.8	37.0	32.0	26.5	35.3	37.7	37.9	32.6	27.0							34.1	36.7	38.6	33.1							33.9	36.6	39.2	34.8		33.7	34.1	34.7	35.2	42.0	
44.0	33.6	35.7	35.9	31.2	26.1		32.4	34.6	36.7	31.9	26.6						31.2	33.6	35.9	32.4	27.0						30.9	33.5	35.9	34.0	28.2	30.8	32.8	33.3	33.7	44.0	
46.0	31.0	32.9	34.7	30.5	25.7	29.7	31.8	33.8	31.2	26.2							28.5	30.8	32.9	31.7	26.7						28.3	30.7	32.9	33.3	27.8	28.1	30.1	32.0	32.3	28.8	46.0
48.0	28.6	30.3	31.9	29.9	25.4	27.3	29.2	31.1	30.5	25.9							26.1	28.2	30.2	31.1	26.3						25.9	28.1	30.2	32.6	27.5	25.7	27.6	29.8	31.0	28.4	48.0
50.0	26.3	27.9	29.5	29.3	25.2	25.1	26.9	28.6	29.9	25.6							23.9	25.9	27.7	30.2	26.0						23.7	25.8	27.7	30.2	27.1	23.5	25.2	27.3	29.8	28.1	50.0
55.0	21.6	22.9	24.0	25.5			20.3	21.8	23.2	24.9							19.2	20.8	22.4	24.3	25.5						18.9	20.7	22.3	24.4	25.7	18.7	20.2	21.9	24.1	25.6	55.0
60.0	17.7	18.7	19.5	20.4			16.4	17.6	18.7	19.9							15.3	16.7	17.9	19.4							15.0	16.5	17.8	19.4		14.8	16.0	17.4	19.2		60.0
65.0	14.4	15.1	15.6				13.2	14.1	14.9								12.0	13.2	14.1	15.1							11.6	13.0	14.1	15.3		11.2	12.4	13.7	15.1		65.0
70.0	10.1						10.2	10.9	11.4								9.0	9.9	10.7								8.6	9.7	10.6			8.2	9.2	10.2	11.4		70.0
75.0							5.9										6.4	7.0									6.0	6.8	7.4			5.5	6.3	7.2		75.0	

4段ESP+12.5mFB	2.5m+45mLJ	208 t	9.7m x 9.0m	AJ	360°	JPN
---------------	------------	-------	-------------	----	------	-----

m		24.1	24.1	24.1	24.1	24.1	28.7	28.7	28.7	28.7	28.7	33.3	33.3	33.3	33.3	33.3	37.9	37.9	37.9	37.9	37.9	42.5	42.5	42.5	42.5	42.5	m

ラフィングジブ

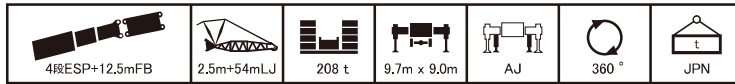

m		24.1	24.1	24.1	24.1	24.1	28.7	28.7	28.7	28.7	28.7	33.3	33.3	33.3	33.3	33.3	37.9	37.9	37.9	37.9	37.9	42.5	42.5	42.5	42.5	42.5	m	
合計ブーム長さm		36.6	36.6	36.6	36.6	36.6	41.2	41.2	41.2	41.2	41.2	45.8	45.8	45.8	45.8	45.8	50.4	50.4	50.4	50.4	50.4	55.0	55.0	55.0	55.0	55.0	m	
°		10	20	30	45	60	10	20	30	45	60	10	20	30	45	60	10	20	30	45	60	12	20	30	45	60	°	
24.0	36.2																										24.0	
26.0	36.2																											26.0
28.0	36.2																											28.0
30.0	36.2																											30.0
32.0	36.2																											32.0
34.0	36.2	36.2																										34.0
36.0	36.2	34.5																										36.0
38.0	35.0	32.8																										38.0
40.0	33.2	31.3																										40.0
42.0	31.4	29.9	27.4																									42.0
44.0	29.9	28.6	26.3																									44.0
46.0	28.4	27.4	25.4																									46.0
48.0	27.1	26.3	24.5																									48.0
50.0	25.9	25.3	23.6	20.0																								50.0
55.0	23.2	23.0	21.7	18.7																								55.0
60.0	19.7	21.0	20.1	17.5	14.3																							60.0
65.0	16.3	17.9	18.7	16.6	13.7																							65.0
70.0	13.5	14.8	16.1	15.7																								70.0
75.0	11.0	12.1	13.1	14.4																								75.0
80.0	8.6	9.3	10.4																									80.0
85.0	6.6	7.2																										85.0

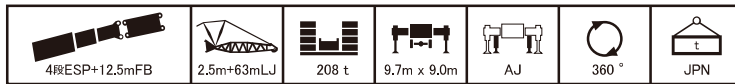

m		24.1	24.1	24.1	24.1	24.1	28.7	28.7	28.7	28.7	28.7	33.3	33.3	33.3	33.3	33.3	37.9	37.9	37.9	37.9	37.9	42.5	42.5	42.5	42.5	42.5	m		
合計ブーム長さm		36.6	36.6	36.6	36.6	36.6	41.2	41.2	41.2	41.2	41.2	45.8	45.8	45.8	45.8	45.8	50.4	50.4	50.4	50.4	50.4	55.0	55.0	55.0	55.0	55.0	m		
°		10	20	30	45	60	10	20	30	45	60	10	20	30	45	60	10	20	30	45	60	12	20	30	45	60	°		
28.0	25.0																											28.0	
30.0	25.0																											30.0	
32.0	25.0																											32.0	
34.0	25.0																											34.0	
36.0	25.0																											36.0	
38.0	25.0	25.0																										38.0	
40.0	25.0	25.0																										40.0	
42.0	25.0	25.0																										42.0	
44.0	25.0	25.0																										44.0	
46.0	25.0	25.0	25.0																									46.0	
48.0	25.0	25.0	24.0																									48.0	
50.0	25.0	25.0	23.1																									50.0	
55.0	23.0	22.5	21.0																									55.0	
60.0	20.6	20.4	19.3	16.3																								60.0	
65.0	18.0	18.7	17.8	15.3	12.1																							65.0	
70.0	15.1	16.7	16.4	14.3	11.5	14.0	15.8	16.9	14.7	11.8																		70.0	
75.0	12.6	14.0	15.3	13.5	11.1	11.5	13.0	14.6	13.9	11.3	10.4	12.2	13.9	14.2	11.6													75.0	
80.0	10.4	11.6	12.7	12.9																									80.0
85.0	8.3	9.4	10.4	11.5																									85.0
90.0	6.5	7.3	8.1																										90.0
95.0		5.3																											95.0

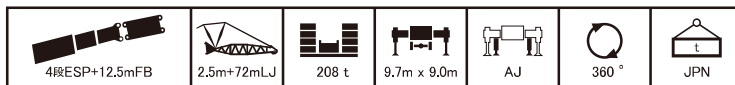

m		24.1	24.1	24.1	24.1	24.1	28.7	28.7	28.7	28.7	28.7	33.3	33.3	33.3	33.3	33.3	37.9	37.9	37.9	37.9	37.9	42.5	42.5	42.5	42.5	42.5	m	
合計ブーム長さm		36.6	36.6	36.6	36.6	36.6	41.2	41.2	41.2	41.2	41.2	45.8	45.8	45.8	45.8	45.8	50.4	50.4	50.4	50.4	50.4	55.0	55.0	55.0	55.0	55.0	m	
°		10	20	30	45	60	10	20	30	45	60	10	20	30	45	60	10	20	30	45	60	12	20	30	45	60	°	
30.0	20.5																											30.0
32.0	20.5																											32.0
34.0	20.5																											34.0
36.0	20.5																											36.0
38.0	20.5																											38.0
40.0	20.5																											40.0
42.0	20.5	20.2																										42.0
44.0	20.5	19.6																										44.0
46.0	20.5	19.1																										46.0
48.0	20.3	18.6																										48.0
50.0	19.7	18.1																										50.0
55.0	18.4	17.0	15.8																									55.0
60.0	17.2	16.0	15.0																									60.0
65.0	16.2	15.2	14.3	13.0																								65.0
70.0	15.1	14.4	13.6	12.1																								70.0
75.0	13.1	13.7	13.1	11.3	8.7																							75.0
80.0	10.9	12.4	12.3	10.6	8.3	9.8	11.5	12.6	10.9	8.5	8.7	10.6	12.4	11.1	8.7	7.8	10.0	11.9	11.3	8.9	7.5	9.3	11.0	11.0	9.3	80.0		
85.0	9.0	10.3	11.4	10.0	7.9	7.7	9.3	10.8	10.3	8.2	6.6	8.4	10.0	10.5	8.4	5.7	7.7	9.6	10.8	8.5	5.3	7.0	9.0	11.0	9.0	85.0		
90.0	7.1	8.3	9.4	9.5																								90.0
95.0	5.4	6.4	7.4	8.5																								95.0
100.0	3.9	4.7	5.3																									100.0
105.0		3.0																										105.0

ラフィングジブ

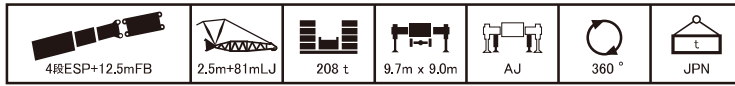

吊り高さ	24.1	24.1	24.1	24.1	24.1	28.7	28.7	28.7	28.7	28.7	33.3	33.3	33.3	33.3	33.3	37.9	37.9	37.9	37.9	37.9	42.5	42.5	42.5	42.5	42.5	m	
合計ブーム長さ	36.6	36.6	36.6	36.6	36.6	41.2	41.2	41.2	41.2	41.2	45.8	45.8	45.8	45.8	45.8	50.4	50.4	50.4	50.4	50.4	55.0	55.0	55.0	55.0	55.0	m	
傾斜角	10	20	30	45	60	10	20	30	45	60	10	20	30	45	60	10	20	30	45	60	12	20	30	45	60	°	
34.0	15.0					13.8																				34.0	
36.0	15.0					13.8					12.6																36.0
38.0	15.0					13.8					12.6					9.1											38.0
40.0	15.0					13.8					12.6					9.1											40.0
42.0	15.0					13.8					12.6					9.1						8.1					42.0
44.0	15.0					13.8					12.6					9.1						8.1					44.0
46.0	15.0	15.0				13.8					12.6					9.1						8.1					46.0
48.0	15.0	15.0				13.8	13.8				12.6	12.6				9.1						8.1					48.0
50.0	15.0	15.0				13.8	13.8				12.6	12.6				9.1	9.1					8.1					50.0
55.0	15.0	15.0				13.8	13.8				12.6	12.6				9.1	9.1					8.1	8.1				55.0
60.0	15.0	15.0	14.9			13.8	13.8	13.8			12.6	12.6	12.6			9.1	9.1					8.1	8.1				60.0
65.0	14.8	14.6	13.5			13.8	13.8	13.7			12.6	12.6	12.6			9.1	9.1	9.1				8.1	8.1	8.1			65.0
70.0	13.3	13.2	12.3			13.6	13.5	12.5			12.6	12.6	12.6			9.1	9.1	9.1				8.1	8.1	8.1			70.0
75.0	11.9	12.0	11.2	9.3		12.1	12.3	11.5	9.5		11.1	12.5	11.7	9.6		9.1	9.1	9.1				8.1	8.1	8.1			75.0
80.0	10.7	10.9	10.3	8.5		10.0	11.2	10.6	8.8		8.8	11.0	10.8	9.0		7.9	9.1	9.1	9.1			7.6	8.1	8.1	8.1		80.0
85.0	9.1	9.9	9.5	7.9	5.8	7.9	9.7	9.7	8.2	6.0	6.7	8.8	10.0	8.4	6.2	5.9	8.1	9.1	8.6			5.5	7.4	8.1	8.1		85.0
90.0	7.2	8.7	8.7	7.4	5.4	6.0	7.7	9.0	7.6	5.7	4.8	6.7	8.6	7.8	5.8	4.0	6.0	8.0	8.0	6.0			5.3	7.4	8.1	6.4	90.0
95.0	5.5	6.8	8.1	6.9	5.2	4.3	5.8	7.3	7.1	5.4	3.2	4.9	6.5	7.4	5.6	4.2	6.0	7.6	5.7					5.4	7.9	6.1	95.0
100.0	4.0	5.1	6.2	6.5		4.1	5.4	6.7				3.2	4.6	6.6	5.4				4.1	6.2	5.5				5.9	5.8	100.0
105.0		3.6	4.5					3.7	5.0					4.5					4.2							3.8	105.0

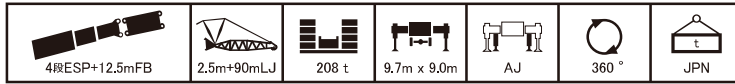

吊り高さ	24.1	24.1	24.1	24.1	24.1	28.7	28.7	28.7	28.7	28.7	33.3	33.3	33.3	33.3	33.3	37.9	37.9	37.9	37.9	37.9	42.5	42.5	42.5	42.5	42.5	m		
合計ブーム長さ	36.6	36.6	36.6	36.6	36.6	41.2	41.2	41.2	41.2	41.2	45.8	45.8	45.8	45.8	45.8	50.4	50.4	50.4	50.4	50.4	55.0	55.0	55.0	55.0	55.0	m		
傾斜角	10	20	30	45	60	10	20	30	45	60	10	20	30	45	60	10	20	30	45	60	12	20	30	45	60	°		
36.0	8.5					7.9					7.2																36.0	
38.0	8.5					7.9					7.2					6.5											38.0	
40.0	8.5					7.9					7.2					6.5											40.0	
42.0	8.5					7.9					7.2					6.5											42.0	
44.0	8.5					7.9					7.2					6.5						5.7					44.0	
46.0	8.5					7.9					7.2					6.5						5.7					46.0	
48.0	8.5					7.9					7.2					6.5						5.7					48.0	
50.0	8.5	8.5				7.9					7.2					6.5						5.7					50.0	
55.0	8.5	8.3				7.9	7.9				7.2	7.2				6.5	6.5					5.7	5.7				55.0	
60.0	8.5	7.6				7.9	7.7				7.2	7.2				6.5	6.5					5.7	5.7				60.0	
65.0	7.8	7.0	6.3			7.9	7.1	6.4			7.2	7.2	6.4			6.5	6.5					5.7	5.7				65.0	
70.0	7.1	6.4	5.8			7.4	6.6	5.9			7.2	6.7	6.0			6.5	6.5	6.1				5.7	5.7	5.7			70.0	
75.0	6.6	6.0	5.4			6.8	6.1	5.5			7.0	6.2	5.6			6.5	6.4	5.7				5.6	5.7	5.7			75.0	
80.0	6.0	5.5	5.0	4.5		6.3	5.7	5.1	4.5		6.5	5.8	5.2			6.5	6.0	5.3				5.4	5.7	5.5			80.0	
85.0	5.6	5.1	4.7	4.2		5.8	5.3	4.8	4.3		6.0	5.4	4.9	4.3		6.1	5.6	5.0	4.3			5.2	5.7	5.2	4.4		85.0	
90.0	5.2	4.8	4.4	4.0		5.4	4.9	4.5	4.1		5.1	5.1	4.6	4.1		4.3	5.2	4.7	4.1			5.4	4.9	4.2			90.0	
95.0	4.8	4.5	4.2	3.8	3.5	4.6	4.6	4.3	3.9	3.6	3.5	4.8	4.4	3.9	3.6		4.7	4.5	4.0	3.6			4.6	4.1		95.0		
100.0	4.3	4.2	4.0	3.7	3.2	3.1	4.3	4.1	3.7	3.4		3.7	4.1	3.8	3.5				4.2	3.8	3.5			4.3	3.9	3.6	100.0	
105.0		4.0	3.8	3.5	3.0		3.1	3.9	3.6	3.2				3.7	3.7	3.4						3.7	3.4			3.8	3.4	105.0
110.0			3.6	3.4					3.4													3.6	3.3					

ラフィングジブ



m		24.1	24.1	24.1	24.1	24.1	28.7	28.7	28.7	28.7	28.7	33.3	33.3	33.3	33.3	33.3	m
合計ブーム長さ m		49.1	49.1	49.1	49.1	49.1	53.7	53.7	53.7	53.7	53.7	58.3	58.3	58.3	58.3	58.3	m
°		10	20	30	45	60	10	20	30	45	60	10	20	30	45	60	°
m	20.0	70.8					61.0										20.0
	22.0	70.8					61.0					52.5					22.0
	24.0	70.5	70.7				61.0	61.0				52.5					24.0
	26.0	66.4	66.6				61.0	61.0				52.5	52.5				26.0
	28.0	62.6	62.8	62.9			59.9	60.5	59.1			50.4	52.5				28.0
	30.0	58.4	59.2	59.4			56.8	57.4	57.4			48.3	50.4	52.0			30.0
	32.0	53.0	56.0	56.1	49.2		51.5	54.6	54.5			46.1	48.5	49.7			32.0
	34.0	47.7	50.6	53.1	48.0		46.2	49.4	51.8	48.7		44.1	46.5	47.2			34.0
	36.0	43.0	45.8	48.3	47.0	38.9	41.6	44.5	47.2	47.6		40.3	43.4	44.8	45.5		36.0
	38.0	39.0	41.4	43.8	46.0	38.4	37.5	40.2	42.7	46.0	38.8	36.2	39.1	41.7	43.2	39.2	38.0
	40.0	35.3	37.6	39.7	42.5	37.9	33.9	36.4	38.7	41.7	38.4	32.6	35.2	37.7	40.9	38.8	40.0
	42.0	32.1	34.2	36.1	38.6	37.5	30.6	32.9	35.1	37.8	38.0	29.4	31.8	34.1	37.0	38.4	42.0
	44.0	29.1	31.1	32.9	35.1	36.6	27.7	29.9	31.8	34.3	36.0	26.4	28.7	30.8	33.5	35.4	44.0
	46.0	26.5	28.3	29.9	32.0	33.2	25.1	27.1	28.9	31.1	32.6	23.8	25.9	27.9	30.4	32.0	46.0
	48.0	24.0	25.7	27.2	29.1	30.1	22.7	24.5	26.2	28.2	29.5	21.4	23.4	25.2	27.5	28.9	48.0
	50.0	21.8	23.4	24.8	26.4		20.5	22.2	23.7	25.6		19.2	21.1	22.7	24.8	26.1	50.0
	55.0	17.1	18.3	19.4	20.6		15.7	17.1	18.4	19.8		14.5	16.0	17.4	19.0		55.0
60.0	13.2	14.2	15.0			11.8	13.0	14.0	15.0		10.6	11.9	13.0	14.2		60.0	
65.0	9.9	10.6	11.2			8.6	9.5	10.2			7.3	8.4	9.3	10.2		65.0	
70.0	7.1	7.6				5.6	6.3	6.9				5.2	5.9			70.0	

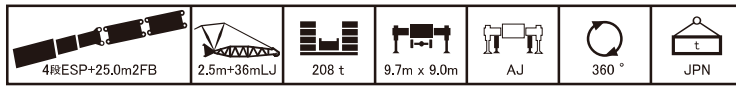

m		24.1	24.1	24.1	24.1	24.1	28.7	28.7	28.7	28.7	28.7	33.3	33.3	33.3	33.3	33.3	m
合計ブーム長さ m		49.1	49.1	49.1	49.1	49.1	53.7	53.7	53.7	53.7	53.7	58.3	58.3	58.3	58.3	58.3	m
°		10	20	30	45	60	10	20	30	45	60	10	20	30	45	60	°
m	22.0	52.2															22.0
	24.0	52.2					46.1										24.0
	26.0	52.2					46.1					40.5					26.0
	28.0	52.2	52.2				46.1					40.5					28.0
	30.0	52.2	52.2				46.1	46.1				40.5	40.5				30.0
	32.0	52.2	51.9				46.1	46.1				40.5	40.5				32.0
	34.0	49.5	49.7	44.5			46.1	46.1	46.1			40.5	40.5				34.0
	36.0	44.8	47.6	43.0			43.9	46.1	45.5			38.5	40.5	40.5			36.0
	38.0	40.7	43.9	41.7			39.8	43.3	44.1			36.5	39.0	40.5			38.0
	40.0	37.0	40.0	40.4	34.2		36.1	39.3	42.3			34.8	37.2	38.7			40.0
	42.0	33.7	36.5	39.2	33.5		32.8	35.8	38.7	35.1		31.5	34.7	36.9	35.5		42.0
	44.0	30.7	33.4	35.9	32.8	27.3	29.8	32.6	35.3	34.3		28.5	31.5	34.4	34.8		44.0
	46.0	28.0	30.5	32.8	32.1	26.9	27.1	29.8	32.3	33.6	28.0	25.8	28.7	31.3	34.1	28.3	46.0
	48.0	25.6	27.9	30.1	31.5	26.6	24.7	27.1	29.5	32.6	27.7	23.4	26.0	28.6	31.9	28.0	48.0
	50.0	23.4	25.5	27.5	30.2	26.3	22.4	24.7	26.9	29.8	27.4	21.2	23.7	26.0	29.1	27.7	50.0
	55.0	18.5	20.3	22.0	24.2	25.6	17.6	19.6	21.4	23.7	25.3	16.3	18.5	20.5	23.0	24.8	55.0
	60.0	14.6	16.1	17.5	19.1		13.6	15.3	16.8	18.7		12.4	14.2	15.9	18.0	19.3	60.0
65.0	11.3	12.5	13.6	14.9		10.3	11.7	13.0	14.4		9.1	10.6	12.0	13.7		65.0	
70.0	8.5	9.5	10.3			7.4	8.6	9.6	10.7		6.1	7.6	8.7	10.0		70.0	
75.0	6.0	6.8	7.4				5.8	6.7					5.7			75.0	

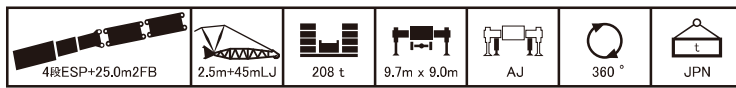

m		24.1	24.1	24.1	24.1	24.1	28.7	28.7	28.7	28.7	28.7	33.3	33.3	33.3	33.3	33.3	m
合計ブーム長さ m		49.1	49.1	49.1	49.1	49.1	53.7	53.7	53.7	53.7	53.7	58.3	58.3	58.3	58.3	58.3	m
°		10	20	30	45	60	10	20	30	45	60	10	20	30	45	60	°
m	24.0	38.5															24.0
	26.0	38.5					34.5										26.0
	28.0	38.5					34.5					30.8					28.0
	30.0	38.5					34.5					30.8					30.0
	32.0	38.5	38.5				34.5					30.8					32.0
	34.0	38.5	38.5				34.5	34.5				30.8					34.0
	36.0	38.5	38.5				34.5	34.5				30.8	30.8				36.0
	38.0	38.5	38.5	35.6			34.5	34.5				30.8	30.8				38.0
	40.0	38.5	38.0	34.4			34.5	34.5	34.5			30.8	30.8				40.0
	42.0	35.5	36.5	33.2			34.1	34.5	33.7			29.3	30.8	30.8			42.0
	44.0	32.5	35.1	32.2			31.1	34.5	32.6			28.0	29.5	30.8			44.0
	46.0	29.7	32.8	31.2	26.4		28.3	31.6	31.6			26.8	28.5	29.8			46.0
	48.0	27.2	30.1	30.2	25.8		25.9	28.9	30.7	26.1		24.5	27.5	28.8			48.0
	50.0	25.0	27.6	29.4	25.2		23.6	26.5	29.3	25.6		22.3	25.4	28.3	25.9		50.0
	55.0	20.1	22.4	24.6	24.0	20.0	18.7	21.2	23.6	24.3	20.2	17.4	20.1	22.7	24.6	20.5	55.0
	60.0	16.0	18.0	19.9	22.4	19.4	14.7	16.9	18.9	21.7	19.7	13.4	15.8	18.0	20.9	19.9	60.0
	65.0	12.7	14.4	15.9	18.0	19.0	11.3	13.2	15.0	17.2	18.8	10.1	12.1	14.0	16.5	18.3	65.0
70.0	9.8	11.2	12.6	14.2		8.5	10.1	11.6	13.4		7.2	9.0	10.7	12.7		70.0	
75.0	7.3	8.5	9.6	10.8		5.9	7.4	8.6	10.1			6.3	7.7	9.4		75.0	
80.0	5.1	6.1	7.0					6.0	7.1				5.0	6.5		80.0	

ラフィングジブ

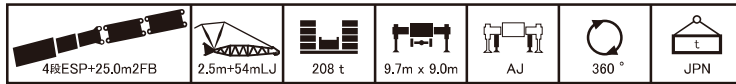

m		24.1	24.1	24.1	24.1	24.1	28.7	28.7	28.7	28.7	28.7	33.3	33.3	33.3	33.3	33.3	m
合計ブーム長さ m		49.1	49.1	49.1	49.1	49.1	53.7	53.7	53.7	53.7	53.7	58.3	58.3	58.3	58.3	58.3	m
°		10	20	30	45	60	10	20	30	45	60	10	20	30	45	60	°
m	28.0	29.4															28.0
	30.0	29.4					26.6					24.1					30.0
	32.0	29.4					26.6					24.1					32.0
	34.0	29.4					26.6					24.1					34.0
	36.0	29.4	29.4				26.6					24.1					36.0
	38.0	29.4	29.4				26.6	26.6				24.1					38.0
	40.0	29.4	29.4				26.6	26.6				24.1	24.1				40.0
	42.0	29.4	29.4				26.6	26.6				24.1	24.1				42.0
	44.0	29.4	29.4	27.2			26.6	26.6				24.1	24.1				44.0
	46.0	29.4	28.8	26.3			26.6	26.6	26.6			24.1	24.1				46.0
	48.0	28.1	27.7	25.5			26.6	26.6	25.8			23.7	24.1	24.1			48.0
	50.0	25.8	26.7	24.7			24.5	26.6	25.0			23.1	23.7	24.1			50.0
	55.0	20.9	23.6	22.9	19.5		19.5	22.5	23.2	19.8		18.2	21.4	23.6			55.0
	60.0	16.8	19.2	21.3	18.5	15.1	15.5	18.1	20.6	18.7		14.2	17.0	19.7	19.0		60.0
	65.0	13.4	15.5	17.5	17.5	14.5	12.1	14.4	16.6	17.8	14.7	10.8	13.3	15.7	18.1	14.9	65.0
	70.0	10.5	12.3	14.1	16.5	14.1	9.2	11.2	13.1	15.7	14.3	7.9	10.1	12.2	15.1	14.5	70.0
	75.0	8.0	9.6	11.1	13.1		6.7	8.5	10.2	12.4	13.9	5.4	7.4	9.2	11.7	13.4	75.0
80.0	5.9	7.2	8.5	10.1			6.1	7.5	9.4				6.6	8.7		80.0	
85.0		5.0	6.2	7.3				5.2	6.6					6.0		85.0	

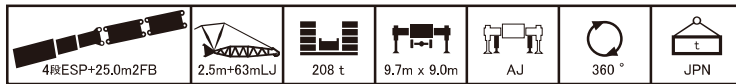



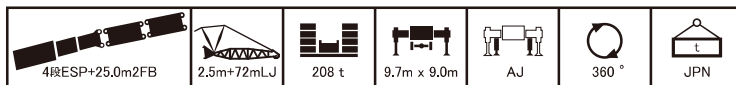



m		24.1	24.1	24.1	24.1	24.1	28.7	28.7	28.7	28.7	28.7	33.3	33.3	33.3	33.3	33.3	m
合計ブーム長さ m		49.1	49.1	49.1	49.1	49.1	53.7	53.7	53.7	53.7	53.7	58.3	58.3	58.3	58.3	58.3	m
°		10	20	30	45	60	10	20	30	45	60	10	20	30	45	60	°
m	30.0	22.1															30.0
	32.0	22.1					20.1										32.0
	34.0	22.1					20.1					18.3					34.0
	36.0	22.1					20.1					18.3					36.0
	38.0	22.1					20.1					18.3					38.0
	40.0	22.1	22.1				20.1					18.3					40.0
	42.0	22.1	22.1				20.1	20.1				18.3					42.0
	44.0	22.1	22.1				20.1	20.1				18.3	18.3				44.0
	46.0	22.1	22.1				20.1	20.1				18.3	18.3				46.0
	48.0	22.1	22.1				20.1	20.1				18.3	18.3				48.0
	50.0	22.1	22.1	22.1			20.1	20.1				18.3	18.3				50.0
	55.0	22.1	22.1	21.5			20.1	20.1	20.1			18.3	18.3	18.3			55.0
	60.0	18.7	21.3	19.8			17.4	20.1	20.1			16.1	18.3	18.3			60.0
	65.0	15.2	17.7	18.4	15.7		14.0	16.6	19.1	16.3		12.7	15.6	18.3	16.5		65.0
	70.0	12.3	14.5	16.6	14.9	11.9	11.0	13.4	15.7	15.4	12.4	9.8	12.4	14.8	15.6		70.0
	75.0	9.8	11.7	13.5	14.1	11.5	8.5	10.6	12.6	14.6	11.9	7.3	9.6	11.8	14.8	12.1	75.0
	80.0	7.6	9.2	10.9	13.1	11.2	6.3	8.2	10.0	12.4	11.6	5.0	7.1	9.1	11.8	11.7	80.0
85.0	5.6	7.1	8.5	10.3		4.2	6.0	7.6	9.7	11.1		4.9	6.7	9.0	10.7	85.0	
90.0	3.7	5.1	6.3	7.8			3.9	5.4	7.2				4.5	6.5		90.0	
95.0		3.2	4.3	5.4				3.3	4.8					4.1		95.0	



m		24.1	24.1	24.1	24.1	24.1	28.7	28.7	28.7	28.7	28.7	33.3	33.3	33.3	33.3	33.3	m
合計ブーム長さ m		49.1	49.1	49.1	49.1	49.1	53.7	53.7	53.7	53.7	53.7	58.3	58.3	58.3	58.3	58.3	m
°		10	20	30	45	60	10	20	30	45	60	10	20	30	45	60	°
m	34.0	16.8					15.3										34.0
	36.0	16.8					15.3					14.0					36.0
	38.0	16.8					15.3					14.0					38.0
	40.0	16.8					15.3					14.0					40.0
	42.0	16.8					15.3					14.0					42.0
	44.0	16.8					15.3					14.0					44.0
	46.0	16.8	16.8				15.3	15.3				14.0					46.0
	48.0	16.8	16.8				15.3	15.3				14.0	14.0				48.0
	50.0	16.8	16.8				15.3	15.3				14.0	14.0				50.0
	55.0	16.8	16.8	16.1			15.3	15.3				14.0	14.0				55.0
	60.0	16.8	16.7	15.4			15.3	15.3	15.3			14.0	14.0	14.0			60.0
	65.0	15.9	15.9	14.7			14.6	15.3	14.8			13.4	14.0	14.0			65.0
	70.0	12.9	15.1	14.1	12.7		11.7	14.4	14.3	12.9		10.5	13.4	14.0			70.0
	75.0	10.4	12.6	13.6	12.0		9.1	11.6	13.7	12.2		7.9	10.6	13.1	12.3		75.0
	80.0	8.2	10.1	12.1	11.3	8.9	6.9	9.1	11.2	11.5	9.0	5.7	8.1	10.4	11.7	9.1	80.0
	85.0	6.2	8.0	9.7	10.7	8.5	4.9	6.9	8.8	10.9	8.7		5.9	8.0	10.9	8.8	85.0
	90.0	4.4	6.1	7.6	9.6	8.2		5.0	6.7	9.0	8.4			5.9	8.4	8.5	90.0
95.0		4.2	5.6	7.4				4.7	6.7					6.1	7.7	95.0	
100.0			3.7	5.2					4.6					3.9		100.0	

ラフィングジブ



 4段ESP+25.0m2FB	 2.5m+81mLJ	 208 t	 9.7m x 9.0m	 AJ	 360°	 JPN
--	--	---	---	--	--	---

	m	24.1	24.1	24.1	24.1	24.1	28.7	28.7	28.7	28.7	28.7	33.3	33.3	33.3	33.3	33.3	m
合計ブーム長さ m		49.1	49.1	49.1	49.1	49.1	53.7	53.7	53.7	53.7	53.7	58.3	58.3	58.3	58.3	58.3	m
	°	10	20	30	45	60	10	20	30	45	60	10	20	30	45	60	°
 m	36.0	12.1															36.0
	38.0	12.1					11.1										38.0
	40.0	12.1					11.1					10.1					40.0
	42.0	12.1					11.1					10.1					42.0
	44.0	12.1					11.1					10.1					44.0
	46.0	12.1					11.1					10.1					46.0
	48.0	12.1					11.1					10.1					48.0
	50.0	12.1	12.1				11.1	11.1				10.1					50.0
	55.0	12.1	12.1				11.1	11.1				10.1	10.1				55.0
	60.0	12.1	12.1				11.1	11.1				10.1	10.1				60.0
	65.0	12.1	12.1	12.1			11.1	11.1	11.1			10.1	10.1	10.1			65.0
	70.0	12.1	12.1	12.1			11.1	11.1	11.1			10.1	10.1	10.1			70.0
	75.0	10.6	12.1	11.9	9.8		9.3	11.1	11.1			8.2	10.1	10.1			75.0
	80.0	8.3	10.6	11.0	9.1		7.1	9.6	11.1	9.3		6.0	8.6	9.3	9.4		80.0
	85.0	6.4	8.4	10.2	8.5	6.3	5.2	7.4	9.6	8.7			6.5	8.8	8.8		85.0
	90.0	4.6	6.5	8.3	8.0	5.9		5.5	7.5	8.2	6.1			6.7	8.3	6.2	90.0
	95.0		4.7	6.4	7.5	5.7			5.5	7.7	5.8				7.4	5.9	95.0
100.0		3.0	4.6	6.6	5.4				6.0	5.6				5.4	5.7	100.0	
105.0				4.7					4.0						5.0	105.0	

6段ESPブーム

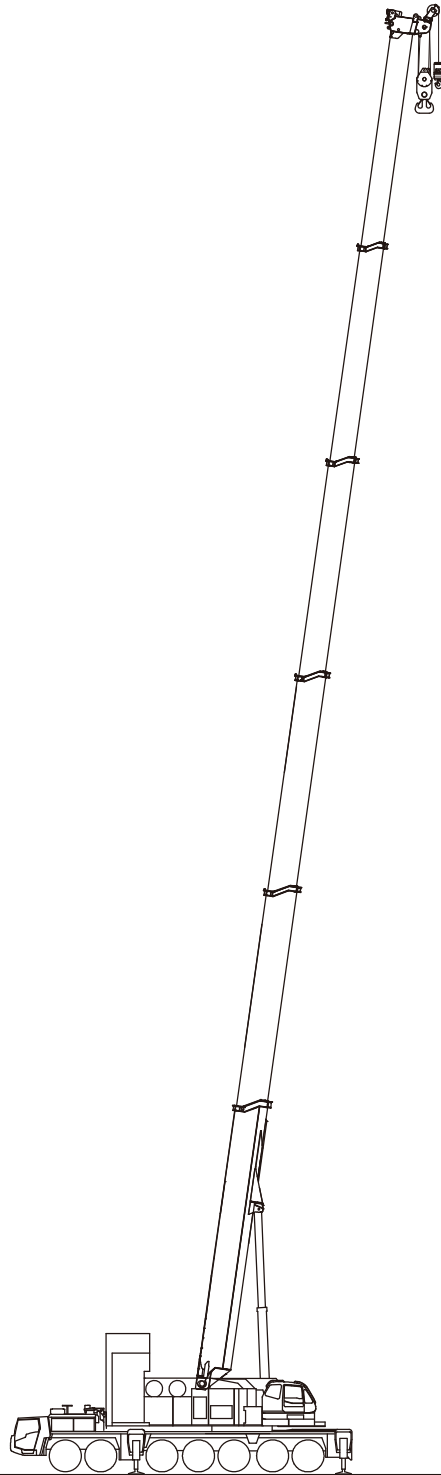

6段ESPブーム



6段ESPブーム作業半径－揚程図

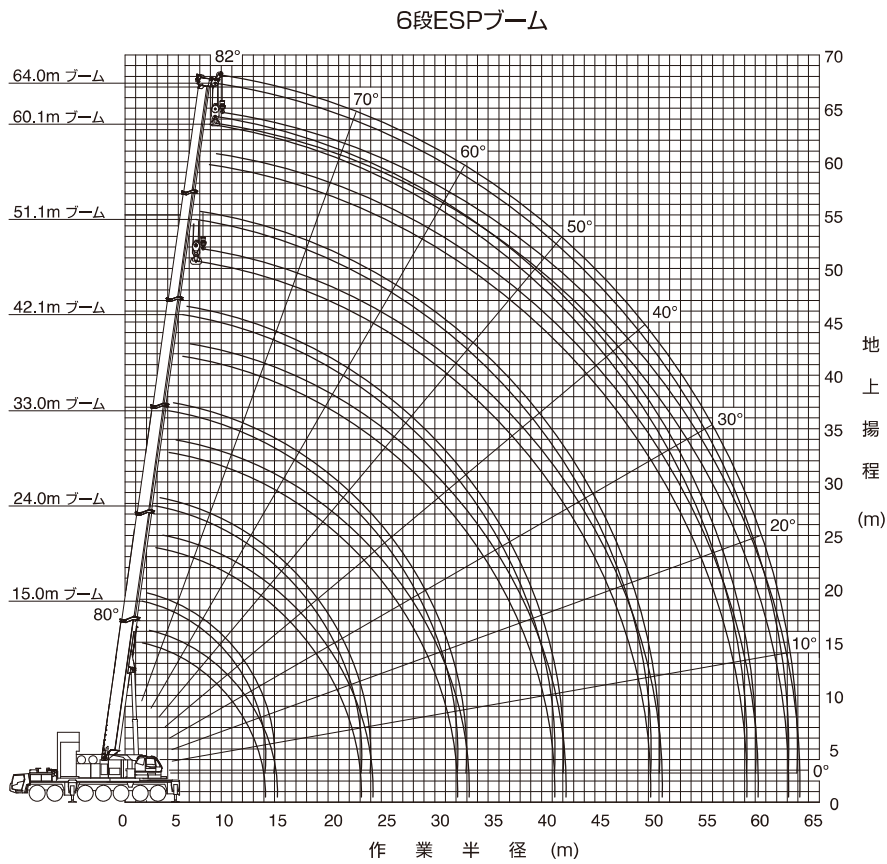

(注意) 1. 上図はブームのたわみを含んでいません。
 2. カウンタウエイト164 t、アウトリガ張出幅9.0m、センタージャッキ、アシストジャッキ使用時の性能を図示しています。

6段ESPブーム



6段ESPブーム定格総荷重表

■ 定格総荷重表注意事項

- ◆性能設定のあるカウンタウエイトとアウトリガ張出幅の組合せを、下表に○印で示します。
◎印は旋回方向によって性能が異なります。
CJ+AJ付はセンタージャッキ、アシストジャッキを装着している状態を示し、AJ付はアシストジャッキを装着している状態を示します。
本仕様書では、**■**の定格総荷重表のみ記載しています。
また、各ブーム長さにおいて異なる伸縮状態の中から最大になる性能を抜粋し記載しています。
※同じブーム長さでも、ブームの伸長状態によって定格総荷重が異なります。
このため、カウンタウエイトとアウトリガ張出幅の組合せに応じた定格総荷重および他の詳細については、別冊の仕様書を参照してください。

【6段ESPブーム】

アウトリガ張出幅	カウンタウエイト	208 t	195 t	164 t	127 t	94 t	57 t	27 t	0 t
9.0 m (CJ+AJ付)		○ P38	○	○	△	△	△	△	△
9.0 m (AJ付)		○	○	○	○ P38	○ P39	○	○	○
9.0 m		○	○	○	○	○	○	○	○
8.0 m		△	△	△	○	○	○	○	○
7.0 m		△	△	△	△	○	○	○	○
5.8 m		△	△	△	△	△	○	○	○
2.6 m		△	△	△	△	△	△	△	◎

- ◆定格総荷重は、つり具質量とフック質量 (350tアタッチメント付フック:3,900kg、350tフック:3,460kg、150tフック:2,400kg、12.5tフック:500kg)を含んだ値を示します。
- ◆定格総荷重は、ブームのたわみを含んだ実際の作業半径に基づいています。
- ◆各状態ごとの標準巻掛本数は別冊の仕様書を参照してください。
- ◆シングルトップ使用時の巻掛本数は1本 (12.5tフック使用)で、定格総荷重はブームの定格総荷重からブームに取り付けられているフックの質量を差し引いた値とし、かつ限度は12.5tです。
- ◆定格総荷重は、アウトリガを水平堅土上に設置したときの値です。
- ◆定格総荷重表は、風による影響を含んでいません。瞬間最大風速が10m/s以上の風速では、クレーン作業を中止してください。

定格総荷重表中のシンボル、記号の説明

6段ESP	6 段 ESP の定格総荷重を示します。	360°	吊上げ可能な旋回範囲を示します。 360°旋回可能です。
カウンタウエイト (C/W)	カウンタウエイト (C/W) 組合せを示します。	t JPN	定格総荷重の単位を示します。
アウトリガ張出幅	アウトリガ張出幅を示します。	m	ブーム長さを示します。
CJ+AJ	センタージャッキ (CJ)、アシストジャッキ (AJ) を装着している状態を示します。	m	作業半径を示します。
AJ	アシストジャッキ (AJ) を装着している状態を示します。		

6段ESPブーム



6段ESP	208 t	9.7m x 9.0m	CJ+AJ	360°	JPN
-------	-------	-------------	-------	------	-----

		15.0	19.5	24.0	28.5	33.0	37.6	42.1	46.6	51.1	55.6	60.1	64.0		
m	6.0	300.0													6.0
	7.0	300.0	250.0												7.0
	8.0	266.5	250.0	250.0	195.0										8.0
	9.0	236.9	236.4	232.6	195.0	195.0	170.0	157.0							9.0
	10.0	212.9	212.4	211.9	195.0	195.0	170.0	157.0	147.0	119.6	94.2				10.0
	11.0	193.0	192.4	191.9	191.6	186.9	170.0	157.0	145.2	119.6	94.2	76.4			11.0
	12.0	169.5	175.7	175.2	174.7	173.5	163.6	157.0	139.4	119.6	94.2	76.4	66.8		12.0
	14.0		151.7	152.4	151.8	150.3	150.5	143.0	128.9	112.2	94.2	76.4	66.8		14.0
	16.0		126.9	132.1	131.5	132.8	131.5	130.3	118.7	104.4	91.9	73.7	66.8		16.0
	18.0			116.2	115.6	117.0	115.6	114.4	109.6	97.5	86.5	69.4	64.3		18.0
	20.0			99.0	105.0	104.2	102.7	101.5	101.3	91.3	81.3	65.5	60.9		20.0
	22.0			58.9	94.6	93.7	92.2	91.9	90.7	85.7	76.6	62.0	57.6		22.0
	24.0				81.9	84.8	82.9	82.5	81.1	80.6	72.3	58.8	52.9		24.0
	26.0				57.6	75.9	74.7	73.6	72.2	72.8	68.4	55.9	48.8		26.0
	28.0					67.5	67.3	66.2	64.7	65.3	64.8	53.1	45.3		28.0
	30.0					51.2	61.1	59.9	59.2	59.0	59.8	50.6	42.1		30.0
	32.0						55.8	54.5	55.3	53.6	54.4	48.3	39.4		32.0
	34.0							44.7	49.9	50.6	49.4	46.2	36.9		34.0
	36.0								45.8	46.5	47.0	45.5	44.3	34.7	36.0
	38.0								38.8	42.9	43.5	41.9	42.5	32.7	38.0
	40.0								27.9	39.8	40.3	39.0	40.0	30.9	40.0
42.0									35.5	37.5	37.0	37.1	29.2	42.0	
44.0									28.2	34.9	35.2	34.4	27.7	44.0	
46.0										32.0	33.1	32.1	26.4	46.0	
48.0										26.6	31.0	30.0	25.1	48.0	
50.0											29.1	28.0	23.9	50.0	
52.0											23.3	26.3	22.9	52.0	
54.0												24.7	21.9	54.0	
56.0												20.8	21.0	56.0	
58.0												12.5	20.2	58.0	
60.0													18.1	60.0	
62.0													10.3	62.0	

6段ESP	127 t	9.7m x 9.0m	AJ	360°	JPN
-------	-------	-------------	----	------	-----

		15.0	19.5	24.0	28.5	33.0	37.6	42.1	46.6	51.1	55.6	60.1	64.0		
m	3.0	170.0	170.0												3.0
	3.5	170.0	170.0	170.0											3.5
	4.0	170.0	170.0	170.0											4.0
	4.5	170.0	170.0	170.0	170.0										4.5
	5.0	170.0	170.0	170.0	170.0										5.0
	6.0	170.0	170.0	170.0	170.0	170.0									6.0
	7.0	170.0	170.0	170.0	170.0	170.0	170.0								7.0
	8.0	170.0	170.0	170.0	170.0	170.0	170.0	157.0							8.0
	9.0	170.0	170.0	170.0	170.0	170.0	170.0	157.0	147.0	119.6					9.0
	10.0	170.0	170.0	170.0	170.0	170.0	170.0	157.0	147.0	119.6	94.2				10.0
	11.0	167.6	169.8	170.0	170.0	168.5	170.0	157.0	145.2	119.6	94.2	76.4			11.0
	12.0	152.9	155.0	155.7	155.2	156.6	155.2	154.1	139.4	119.6	94.2	76.4	66.8		12.0
	14.0		123.6	125.3	126.9	125.8	124.2	123.5	121.9	112.2	94.2	76.4	66.8		14.0
	16.0		100.8	103.7	103.8	102.7	101.6	100.5	99.0	99.7	91.9	73.7	66.8		16.0
	18.0			87.2	87.2	86.1	85.1	84.0	85.0	84.0	84.2	69.4	64.3		18.0
	20.0			74.8	74.7	73.7	72.6	71.5	72.5	73.4	71.7	65.5	60.9		20.0
	22.0			58.9	65.0	63.9	62.9	61.8	62.7	63.5	61.9	62.0	57.6		22.0
	24.0				57.3	56.2	55.1	54.0	54.9	55.9	56.4	55.6	52.9		24.0
	26.0				51.2	49.8	48.7	47.9	50.5	50.9	49.9	49.2	48.8		26.0
	28.0					44.6	43.4	45.1	46.3	45.5	44.5	43.8	43.8		28.0
	30.0					40.4	39.3	42.3	41.7	41.0	40.0	39.2	39.2		30.0
32.0						37.2	38.5	37.8	37.1	36.1	35.3	35.3		32.0	
34.0						35.5	35.2	34.5	33.7	32.7	31.9	31.9		34.0	
36.0							32.3	31.6	30.8	29.7	28.9	28.9		36.0	
38.0							29.9	29.0	28.2	27.1	26.3	26.3		38.0	
40.0							27.9	26.8	25.9	24.8	24.0	23.9		40.0	
42.0								24.9	23.9	22.8	21.9	21.9		42.0	
44.0								23.3	22.1	21.0	20.0	20.0		44.0	
46.0									20.5	19.4	18.4	18.3		46.0	
48.0									19.2	17.9	16.8	16.8		48.0	
50.0										16.6	15.5	15.4		50.0	
52.0										15.5	14.2	14.2		52.0	
54.0											13.1	13.0		54.0	
56.0											12.1	12.0		56.0	
58.0											11.3	11.1		58.0	
60.0												10.2		60.0	
62.0												9.6		62.0	

6段ESPブーム



6段ESP	94 t	9.7m x 9.0m	AJ	360°	JPN
-------	------	-------------	----	------	-----

	m	15.0	19.5	24.0	28.5	33.0	37.6	42.1	46.6	51.1	55.6	60.1	64.0	m
	3.0	170.0	170.0											3.0
	3.5	170.0	170.0	170.0										3.5
	4.0	170.0	170.0	170.0										4.0
	4.5	170.0	170.0	170.0	170.0									4.5
	5.0	170.0	170.0	170.0	170.0									5.0
	6.0	170.0	170.0	170.0	170.0	170.0								6.0
	7.0	170.0	170.0	170.0	170.0	170.0	170.0							7.0
	8.0	170.0	170.0	170.0	170.0	170.0	170.0	157.0						8.0
	9.0	170.0	170.0	170.0	170.0	170.0	170.0	157.0	147.0	119.6				9.0
	10.0	170.0	170.0	170.0	170.0	170.0	170.0	157.0	147.0	119.6	94.2			10.0
	11.0	145.8	149.4	150.5	153.2	151.9	149.7	147.9	145.2	119.6	94.2	76.4		11.0
	12.0	126.0	129.3	132.7	132.9	131.7	130.5	129.3	127.6	119.6	94.2	76.4	66.8	12.0
	14.0		102.0	104.0	104.1	103.0	101.9	100.7	101.0	99.9	94.2	76.4	66.8	14.0
	16.0		82.9	84.6	84.7	83.6	82.6	81.4	82.5	83.5	81.7	73.7	66.8	16.0
	18.0			70.8	70.8	69.7	68.7	67.6	68.6	69.5	69.3	69.4	64.3	18.0
	20.0			60.4	60.3	59.3	58.2	59.0	61.4	60.7	59.7	59.0	59.0	20.0
	22.0			52.6	52.2	51.1	51.6	53.7	53.1	52.5	51.4	50.7	50.7	22.0
	24.0				45.8	44.6	47.5	47.1	46.5	45.8	44.8	44.1	44.1	24.0
	26.0				40.7	40.2	42.1	41.7	41.1	40.4	39.4	38.6	38.6	26.0
	28.0					37.6	37.6	37.2	36.6	35.9	34.9	34.1	34.1	28.0
	30.0					34.2	33.9	33.4	32.8	32.0	31.1	30.3	30.3	30.0
	32.0						30.7	30.2	29.5	28.8	27.8	27.0	27.0	32.0
	34.0						28.1	27.4	26.7	25.9	24.9	24.1	24.1	34.0
	36.0							25.0	24.3	23.5	22.5	21.6	21.6	36.0
	38.0								23.0	22.2	21.3	20.3	19.4	38.0
	40.0									21.5	20.3	19.4	18.4	40.0
	42.0										18.8	17.8	16.7	42.0
	44.0										17.5	16.3	15.2	44.0
	46.0											15.0	13.8	46.0
	48.0											13.9	12.6	48.0
	50.0												11.5	50.0
	52.0												10.6	52.0
	54.0													54.0
	56.0												8.3	56.0
	58.0												7.5	58.0
	60.0												6.8	60.0
	62.0												6.5	62.0
													5.7	60.0
													5.2	62.0

フルオートラフィングジブ



フルオートラフィングジブ



6段ESPブーム+フルオートラフィングジブ(FLJ)作業半径-揚程図

64.0m6段ESPブーム+1.7m+フルオートラフィングジブ(FLJ)

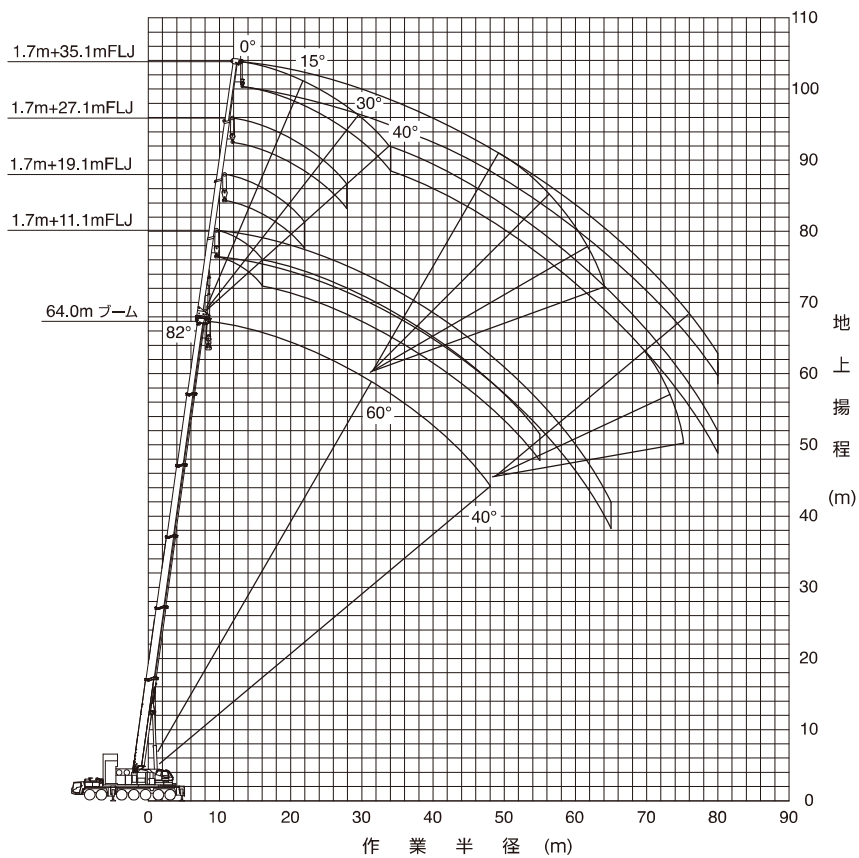

- (注意) 1. 上図はブームおよびジブのたわみを含んでいません。
 2. カウンタウエイト164t、アウトリガ張出幅9.0m、アシストジャッキ使用時の性能を図示しています。

フルオートラフティングジブ



6段ESPブーム+フルオートラフティングジブ(FLJ)定格総荷重表

■ 定格総荷重表注意事項

- ◆性能設定のあるカウンタウエイトとアウトリガ張出幅の組合せを、下表に○印で示します。
AJ付はアシストジャッキを装着している状態を示します。
本仕様書では、の定格総荷重表のみ記載しています。
このため、カウンタウエイトとアウトリガ張出幅の組合せに応じた定格総荷重および他の詳細については、別冊の仕様書を参照してください。

【6段ESPブーム+フルオートラフティングジブ(FLJ)】

アウトリガ張出幅	カウンタウエイト	164 t	127 t	94 t	57 t	27 t
9.0 m (AJ付)		○	○	○	○	○
9.0 m		○	○	○	○	○
8.0 m		△	○	○	○	△
7.0 m		△	○	○	○	△

- ◆定格総荷重は、つり具質量とフック質量(80tフック:1,870kg、25tフック:1,200kg、12.5tフック:500kg)を含んだ値を示します。
- ◆定格総荷重は、ブームとジブのたわみを含んだ実際の作業半径に基づいています。
- ◆各状態ごとの標準巻掛本数は別冊の仕様書を参照してください。
- ◆定格総荷重は、アウトリガを水平堅土上に設置したときの値です。
- ◆定格総荷重表は、風による影響を含んでいません。瞬間最大風速が10m/s以上の風速では、クレーン作業を中止してください。
- ◆定格総荷重表中の太線より上側はクレーンの強度に基づき、下側はクレーンの安定に基づいています。

定格総荷重表中のシンボル、記号の説明

		フルオートラフティングジブ (FLJ) の定格総荷重を示します。
		ブーム長さを示します。
		カウンタウエイト (C/W) 組合せを示します。
		アウトリガ張出幅を示します。
		アシストジャッキ (AJ) を装着している状態を示します。
		吊上げ可能な旋回範囲を示します。 360°旋回可能です。
		定格総荷重の単位を示します。
		フルオートラフティングジブ (FLJ) のジブ長さを示します。
		ジブのオフセット角度を示し、ブームの中心線とジブの中心線のなす角度を示します。
		作業半径を示します。

フルオートラフィングジブ



55.6m 6段ESP	1.7m+FLJ	164 t	9.7m x 9.0m	AJ	360°	JPN

m	11.1				19.1				27.1				35.1				m	
	0	15	30	40	0	15	30	40	0	15	30	40	0	15	30	40		
16.0	48.6				27.2													16.0
18.0	47.2	35.6			26.2				15.5									18.0
20.0	44.6	33.5	25.1	22.0	24.3	15.9			14.7					8.6				20.0
22.0	42.2	31.5	24.1	21.3	22.7	15.1			13.4					8.6				22.0
24.0	39.9	29.8	23.2	20.6	21.2	14.3	11.0		12.4	7.9				8.6				24.0
26.0	37.5	28.2	22.3	20.1	20.0	13.7	10.6	9.3	11.5	7.5				8.0				26.0
28.0	35.1	26.8	21.5	19.5	18.8	13.1	10.3	9.1	10.7	7.1				7.4	4.8			28.0
30.0	32.9	25.5	20.8	19.0	17.6	12.5	9.9	8.8	10.0	6.8	5.1			6.9	4.5			30.0
32.0	31.0	24.3	20.1	18.5	16.6	12.0	9.6	8.6	9.3	6.4	4.9			6.4	4.2			32.0
34.0	29.3	23.2	19.5	18.1	15.7	11.5	9.3	8.4	8.7	6.1	4.7	4.1		6.0	4.0			34.0
36.0	27.8	22.3	19.0	17.7	14.8	11.1	9.1	8.3	8.2	5.9	4.6	4.0		5.6	3.8	2.8		36.0
38.0	26.3	21.3	18.4	17.4	14.1	10.6	8.8	8.1	7.7	5.6	4.4	3.9		5.2	3.6	2.7		38.0
40.0	23.9	20.5	17.9	17.1	13.4	10.3	8.6	8.0	7.3	5.4	4.3	3.8		4.9	3.4	2.6	2.2	40.0
42.0	21.5	19.7	17.5	16.8	12.7	9.9	8.4	7.8	6.9	5.1	4.1	3.7		4.6	3.3	2.5	2.1	42.0
44.0	19.2	19.0	17.1	16.5	12.1	9.6	8.2	7.7	6.6	4.9	4.0	3.6		4.4	3.1	2.4	2.1	44.0
46.0	17.2	18.0	16.7	16.3	11.6	9.3	8.1	7.6	6.2	4.7	3.9	3.5		4.1	3.0	2.3	2.0	46.0
48.0	15.4	16.1	16.4	16.1	11.1	9.0	7.9	7.5	5.9	4.6	3.8	3.4		3.9	2.8	2.2	1.9	48.0
50.0	13.7	14.3	14.7		10.6	8.7	7.7	7.4	5.6	4.4	3.7	3.4		3.7	2.7	2.1	1.9	50.0
55.0	10.1	10.6	10.8		9.6	8.1	7.4	7.3	5.0	4.0	3.5	3.2		3.2	2.4	1.9	1.7	55.0
60.0	7.2	7.5			8.7	7.7	7.2		4.5	3.7	3.3	3.1		2.8	2.2	1.8	1.6	60.0
65.0	4.7				6.9	7.3			4.1	3.5	3.2	3.1		2.5	2.0	1.6	1.5	65.0
70.0					4.6	5.0			3.7	3.3	3.1			2.2	1.8	1.5	1.4	70.0
75.0									3.4	3.1				1.9	1.6	1.4		75.0
80.0									3.2					1.7	1.5	1.4		80.0

60.1m 6段ESP	1.7m+FLJ	164 t	9.7m x 9.0m	AJ	360°	JPN

m	11.1				19.1				27.1				35.1				m		
	0	15	30	40	0	15	30	40	0	15	30	40	0	15	30	40			
16.0	39.6																		16.0
18.0	37.5	32.8			24.9				14.6										18.0
20.0	35.3	31.0			24.8				14.6					8.3					20.0
22.0	33.3	29.3	24.3	21.4	23.2	15.2			13.8					8.3					22.0
24.0	31.4	27.8	23.4	20.8	21.7	14.5			12.7					8.3					24.0
26.0	29.6	26.3	22.6	20.2	20.5	13.8	10.7		11.8	7.5				8.1					26.0
28.0	28.0	24.9	21.9	19.7	19.3	13.2	10.3	9.1	11.0	7.1				7.6					28.0
30.0	26.5	23.6	21.2	19.2	18.2	12.7	10.0	8.9	10.3	6.8				7.1	4.5				30.0
32.0	25.1	22.5	20.5	18.8	17.2	12.2	9.7	8.6	9.6	6.5	5.0			6.6	4.3				32.0
34.0	23.7	21.4	19.9	18.4	16.3	11.7	9.4	8.5	9.0	6.2	4.8	4.1		6.2	4.1				34.0
36.0	22.5	20.4	19.1	18.0	15.4	11.3	9.2	8.3	8.5	5.9	4.6	4.0		5.8	3.9				36.0
38.0	21.4	19.4	18.3	17.6	14.6	10.9	8.9	8.2	8.0	5.7	4.5	3.9		5.4	3.7	2.7			38.0
40.0	20.3	18.6	17.6	17.3	13.9	10.5	8.7	8.0	7.6	5.4	4.3	3.8		5.1	3.5	2.6			40.0
42.0	19.4	17.8	16.9	16.6	13.3	10.1	8.5	7.9	7.2	5.2	4.2	3.7		4.8	3.3	2.5	2.1		42.0
44.0	18.5	17.0	16.2	16.0	12.7	9.8	8.3	7.8	6.8	5.0	4.1	3.6		4.5	3.2	2.4	2.1		44.0
46.0	17.7	16.3	15.6	15.5	12.1	9.5	8.2	7.6	6.5	4.8	3.9	3.5		4.3	3.0	2.3	2.0		46.0
48.0	15.8	15.7	15.1	15.0	11.6	9.2	8.0	7.5	6.2	4.7	3.8	3.5		4.0	2.9	2.2	1.9		48.0
50.0	14.1	14.8	14.6	14.5	11.1	8.9	7.8	7.4	5.9	4.5	3.7	3.4		3.8	2.8	2.2	1.9		50.0
55.0	10.5	11.1	11.4		10.1	8.3	7.5	7.3	5.3	4.1	3.5	3.2		3.3	2.5	2.0	1.7		55.0
60.0	7.6	8.0	8.1		9.2	7.8	7.3	7.2	4.7	3.8	3.3	3.1		2.9	2.2	1.8	1.6		60.0
65.0	5.0	5.3			7.2	7.5	7.1		4.3	3.6	3.2	3.1		2.6	2.0	1.7	1.5		65.0
70.0	3.0				4.9	5.4			3.9	3.3	3.1			2.3	1.8	1.6	1.4		70.0
75.0					3.0	3.3			3.6	3.2	3.0			2.1	1.7	1.5	1.4		75.0
80.0									3.3	3.1				1.8	1.5	1.4			80.0

64.0m 6段ESP	1.7m+FLJ	164 t	9.7m x 9.0m	AJ	360°	JPN

m	11.1				19.1				27.1				35.1				m			
	0	15	30	40	0	15	30	40	0	15	30	40	0	15	30	40				
16.0	28.5																			16.0
18.0	28.5				18.1															18.0
20.0	28.5	28.5			18.1				10.9											20.0
22.0	28.5	27.6	24.5		18.1				10.9					6.5						22.0
24.0	28.5	26.2	23.7	20.9	18.1	14.6			10.9					6.5						24.0
26.0	27.8	24.9	22.9	20.3	18.1	13.9			10.9	7.5				6.5						26.0
28.0	26.3	23.6	21.8	19.8	18.1	13.3	10.3		10.9	7.2				6.5						28.0
30.0	24.9	22.4	20.8	19.4	18.1	12.8	10.0	8.5	10.5	6.9				6.5						30.0
32.0	23.7	21.3	19.8	18.9	17.7	12.3	9.7	8.3	9.8	6.6	5.0			6.5	4.3					32.0
34.0	22.4	20.2	18.9	18.4	16.8	11.9	9.5	8.2	9.2	6.3	4.8			6.4	4.1					34.0
36.0	21.3	19.3	18.1	17.7	15.9	11.4	9.2	8.0	8.7	6.0	4.6	4.0		6.0	3.9					36.0
38.0	20.2	18.4	17.3	16.9	15.1	11.0	9.0	7.9	8.2	5.8	4.5	3.9		5.6	3.7	2.7				38.0
40.0	19.2	17.5	16.6	16.3	14.4	10.7	8.8	7.7	7.8	5.5	4.3	3.8		5.3	3.5	2.6				40.0
42.0	18.3	16.8	15.9	15.7	13.7	10.3	8.6	7.6	7.4	5.3	4.2	3.7		5.0	3.4	2.5				42.0
44.0	17.4	16.0	15.3	15.1	13.1	10.0	8.4	7.5	7.0	5.1	4.1	3.6		4.7	3.2	2.4	2.1			44.0
46.0	16.6	15.4	14.7	14.5	12.5	9.7	8.2	7.4	6.7	4.9	4.0	3.6		4.4	3.1	2.3	2.0			46.0
48.0	15.6	14.7	14.1	14.0	12.0	9.4	8.1	7.3	6.4	4.8	3.9	3.5		4.2	2.9	2.3	1.9			48.0
50.0	13.9	14.1	13.6	13.5	11.5	9.1	7.9	7.2	6.1	4.6	3.8	3.4		4.0	2.8	2.2	1.9			50.0
55.0	10.3	10.9	11.2	11.3	10.2	8.5	7.6	7.0	5.4	4.2	3.5	3.3		3.5	2.5	2.0	1.7			55.0
60.0	7.4	7.8	8.0		9.2	8.0	7.3	6.9	4.9	3.9	3.4	3.1		3.1	2.3	1.8	1.6			60.0
65.0	4.7	5.1			6.9	7.6	7.1		4.4	3.6	3.2	3.1		2.7	2.1	1.7	1.5			65.0
70.0					4.6	5.2	5.6		4.0	3.4	3.1	3.0		2.4	1.9	1.6	1.4			70.0
75.0									3.7	3.2	3.0			2.2	1.7	1.5	1.4			75.0
80.0									2.9	3.1	3.0			1.9	1.6	1.4	1.4			80.0